



Hybrid Inverter

SUN-3K-SG04LP1-24-AU

SUN-3K-SG04LP1-AU

SUN-3.6K-SG04LP1-AU

SUN-5K-SG04LP1-AU

SUN-6K-SG04LP1-AU

User Manual



Contents

1. Safety Introductions	01
2. Product instructions	01-04
2.1 Product Overview	
2.2 Product Size	
2.3 Product Features	
2.4 Basic System Architecture	
2.5 Maintenance of the System	
3. Installation	05-20
3.1 Parts list	
3.2 Mounting instructions	
3.3 Battery connection	
3.4 Grid connection and backup load connection	
3.5 PV Connection	
3.6 CT Connection	
3.6.1 Meter Connection	
3.7 Earth Connection(mandatory)	
3.8 WIFI Connection	
3.9 Wiring System for Inverter	
4. OPERATION	19
4.1 Power ON/OFF	
4.2 Operation and Display Panel	
5. LCD Display Icons	20-33
5.1 Main Screen	
5.2 Solar Power Curve	
5.3 Curve Page-Solar & Load & Grid	
5.4 System Setup Menu	
5.5 Basic Setup Menu	
5.6 Battery Setup Menu	
5.7 System Work Mode Setup Menu	
5.8 Grid Setup Menu	
5.9 Generator Port Use Setup Menu	
5.10 Advanced Function Setup Menu	
5.11 Device Info Setup Menu	
6. Mode	33-34
7. Fault information and processing	35-38
8. Limitation of Liability	38
9. Datasheet	39-40
10. Package and transport inverter	40
11. Disposing of the inverter	40
12. Appendix I	41-42
13. Appendix II	43

About This Manual

The manual mainly describes the product information, guidelines for installation, operation and maintenance. The manual cannot include complete information about the photovoltaic (PV) system.

How to Use This Manual

Read the manual and other related documents before performing any operation on the inverter. Documents must be stored carefully and be available at all times.

Contents may be periodically updated or revised due to product development. The information in this manual is subject to change without notice.

1. Safety Introductions

- This chapter contains important safety and operating instructions. Read and keep this manual for future reference.
- Before using the inverter, please read the instructions and warning signs of the battery and corresponding sections in the instruction manual.
- Do not disassemble the inverter. If you need maintenance or repair, take it to a professional service center.
- Improper reassembly may result in electric shock or fire.
- To reduce risk of electric shock, disconnect all wires before attempting any maintenance or cleaning. Turning off the unit will not reduce this risk.
- Caution: Only qualified personnel can install this device with battery.
- Never charge a frozen battery.
- For optimum operation of this inverter, please follow required specification to select appropriate cable size. It is very important to correctly operate this inverter.
- Be very cautious when working with metal tools on or around batteries. Dropping a tool may cause a spark or short circuit in batteries or other electrical parts, even cause an explosion.
- Please strictly follow installation procedure when you want to disconnect AC or DC terminals. Please refer to "Installation" section of this manual for the details.
- Grounding instructions - this inverter should be connected to a permanent grounded wiring system. Be sure to comply with local requirements and regulation to install this inverter.
- Never cause AC output and DC input short circuited. Do not connect to the mains when DC input short circuits.

2. Product Introduction

This is a multifunctional inverter, combining functions of inverter, solar charger and battery charger to offer uninterruptible power support with portable size. Its comprehensive LCD display offers user configurable and easy accessible button operation such as battery charging, AC/solar charging, and acceptable input voltage based on different applications.

2.1 Product Overview

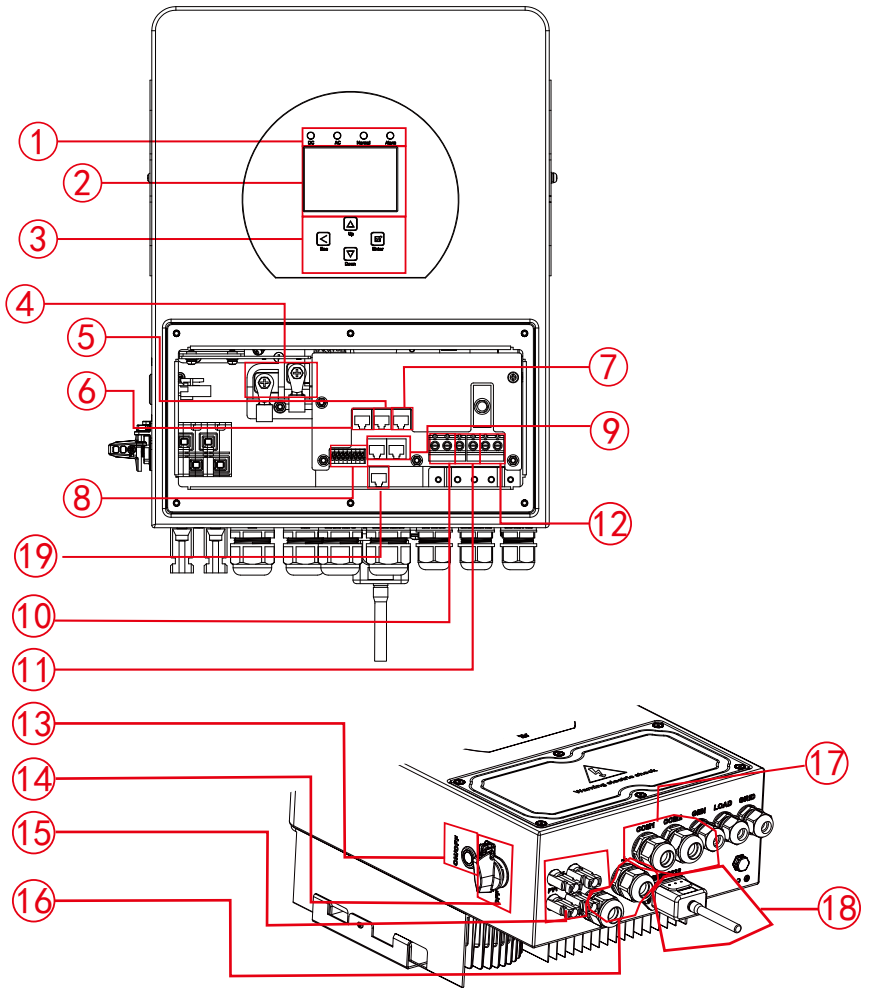

1: Inverter Indicators

2: LCD display

3: Function Buttons

4: Battery input connectors

5: RS 485 Port

6: BMS CAN Port

7: Meter Port

8: Function Port

9: Parallel port

10: Generator input

11: Load

12: Grid

19: DRM Port

13: Power on/off button

14: DC Switch

15: PV input with two MPPT

16: Battery

17: Temperature sensor

18: WiFi Interface

2.2 Product Size

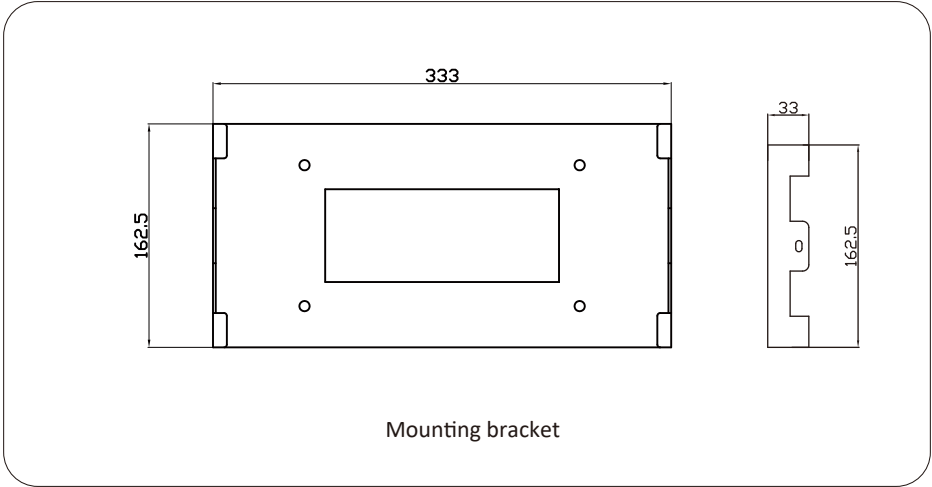
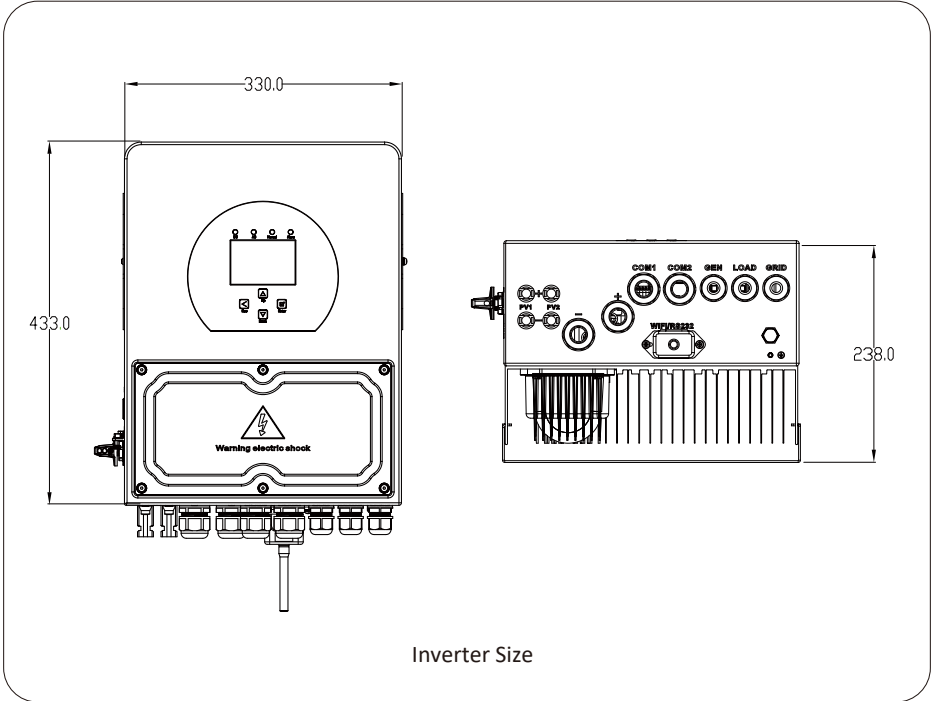

2.3 Product Features

- Self-consumption and feed-in to the grid.
- Auto restart while AC is recovering.
- Programmable supply priority for battery or grid.
- Programmable multiple operation modes: On grid, off grid and UPS.
- Configurable battery charging current/voltage based on applications by LCD setting.
- Configurable AC/Solar/Generator Charger priority by LCD setting.
- Compatible with mains voltage or generator power.
- Overload/over temperature/short circuit protection.
- Smart battery charger design for optimized battery performance
- With limit function, prevent excess power overflow to the grid.
- Supporting WIFI monitoring and build-in 2 strings of MPP trackers
- Smart settable three stages MPPT charging for optimized battery performance.
- Time of use function.
- Smart Load Function.

2.4 Basic System Architecture

The following illustration shows basic application of this inverter.

It also includes following devices to have a Complete running system.

- Generator or Utility
- PV modules

Consult with your system integrator for other possible system architectures depending on your requirements.

This inverter can power all kinds of appliances in home or office environment, including motor type appliances such as refrigerator and air conditioner.

2.5 Maintenance of the System

The inverter is low maintenance, however, it is important that at least twice a year (for dusty environments this may need to be carried out weekly) all the cooling fans, air ducts are cleaned and dust free. Check if there are no fault codes and Lithium battery communication is correct.

Weekly cleaning statement: Suggest micromesh filters as an available option.

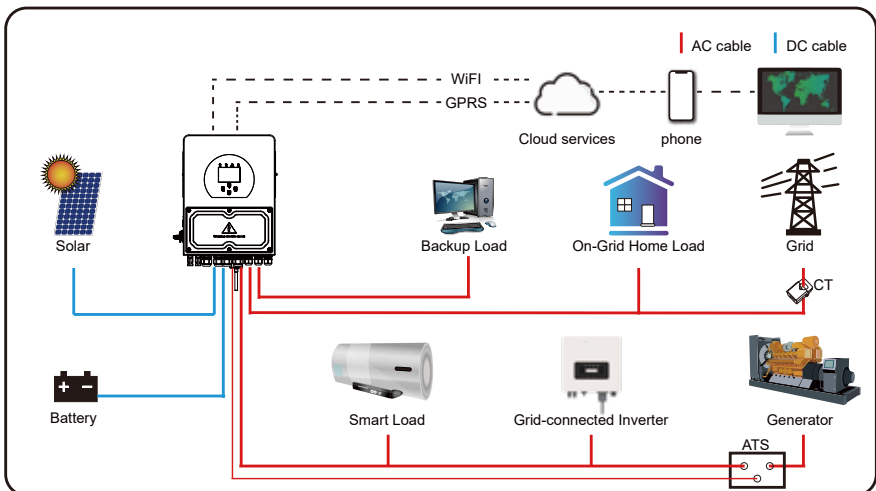

3. Installation

3.1 Parts List

Check the equipment before installation. Please make sure nothing is damaged in the package. You should have received the items in the following package:

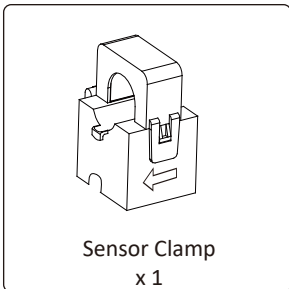
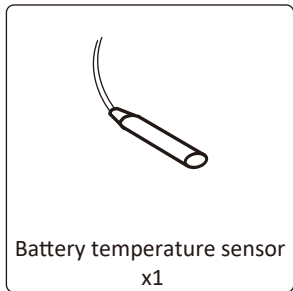
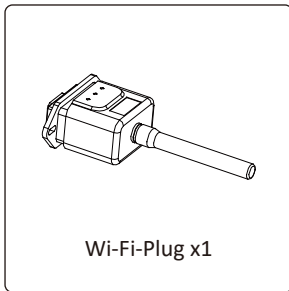
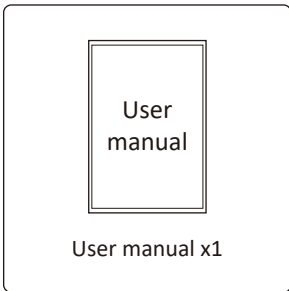
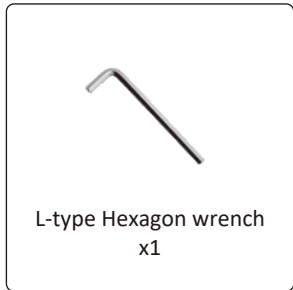
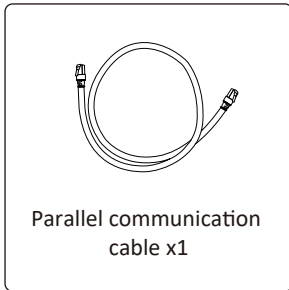
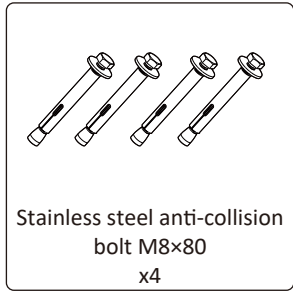
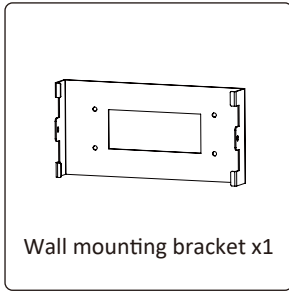
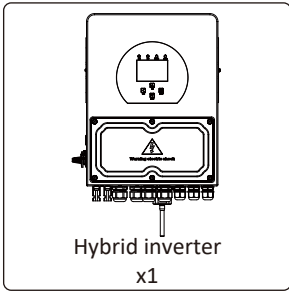

3.2 Mounting instructions

Installation Precaution

This Hybrid inverter is designed for outdoor use(IP65), Please make sure the installation site meets below conditions:

- Not in direct sunlight
- Not in areas where highly flammable materials are stored.
- Not in potential explosive areas.
- Not in the cool air directly.
- Not near the television Antenna or antenna cable.
- Not higher than altitude of about 2000 meters above sea level.
- Not in environment of precipitation or humidity(>95%)

Please AVOID direct sunlight, rain exposure, snow laying up during installation and operation. Before connecting all wires, please take off the metal cover by removing screws as shown below:

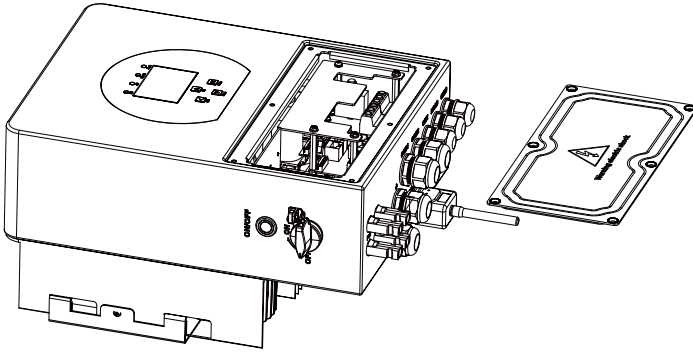

Considering the following points before selecting where to install:

- Please select a vertical wall with load-bearing capacity for installation, suitable for installation on concrete or other non-flammable surfaces, installation is shown below.
- Install this inverter at eye level in order to allow the LCD display to be read at all times.
- The ambient temperature should be between $-25\sim 60^{\circ}\text{C}$ to ensure optimal operation.
- Be sure to keep other objects and surfaces as shown in the diagram to guarantee sufficient heat dissipation and have enough space for removing wires.

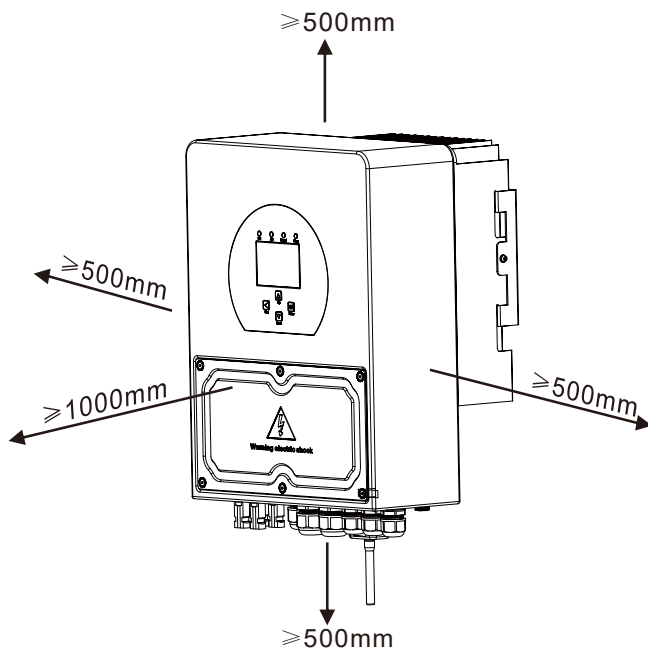

For proper air circulation to dissipate heat, allow a clearance of approx. 50cm to the side and approx. 50cm above and below the unit. And 100cm to the front.

Mounting the inverter

Remember that this inverter is heavy! Please be careful when lifting out from the package. Choose the recommend drill head(as shown in below pic) to drill 4 holes on the wall, 82-90mm deep.

1. Use a proper hammer to fit the expansion bolt into the holes.
2. Carry the inverter and holding it, make sure the hanger aim at the expansion bolt,fix the inverter on the wall.
3. Fasten the screw head of the expansion bolt to finish the mounting.

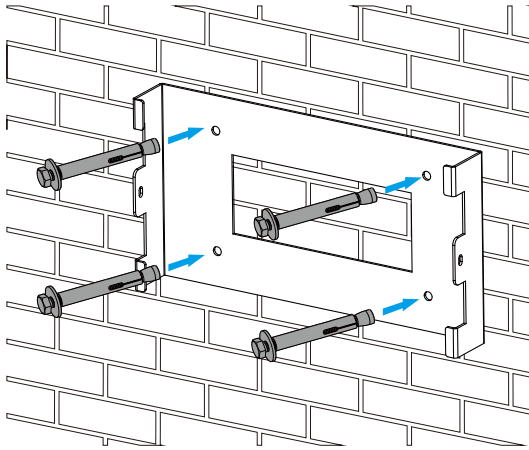

Inverter hanging plate installation

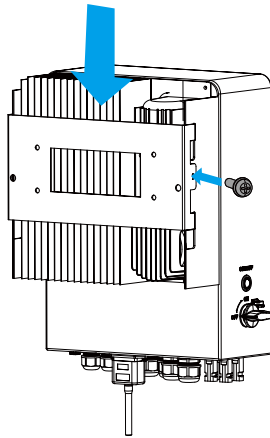

3.3 Battery connection

For safe operation and compliance, a separate DC over-current protector or disconnect device is required between the battery and the inverter. In some applications, switching devices may not be required but over-current protectors are still required. Refer to the typical amperage in the table below for the required fuse or circuit breaker size.

<i>Model</i>	<i>Wire Size</i>	<i>Cable(mm²)</i>	<i>Torque value(max)</i>
3/3.6/5/6Kw	2AWG	33.62	5.2Nm

Chart 3-2 Cable size



All wiring must be performed by a professional person.



Connecting the battery with a suitable cable is important for safe and efficient operation of the system. To reduce the risk of injury, refer to Chart 3-2 for recommended cables.

Please follow below steps to implement battery connection:

1. Please choose a suitable battery cable with correct connector which can well fit into the battery terminals.
2. Use a suitable screwdriver to unscrew the bolts and fit the battery connectors in, then fasten the bolt by the screwdriver, make sure the bolts are tightened with torque of 5.2 N.M in clockwise direction.
3. Make sure polarity at both the battery and inverter is correctly connected.

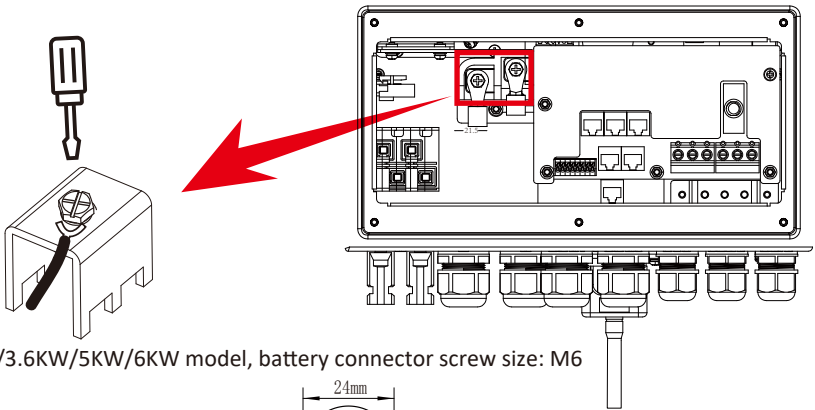

For 3KW/3.6KW/5KW/6KW model, battery connector screw size: M6

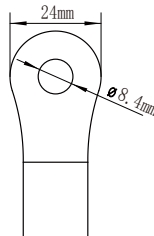

DC Battery Input

4. In case of children touch or insects go into the inverter, Please make sure the inverter connector is fasten to waterproof position by twist it clockwise.



Installation must be performed with care.



Before making the final DC connection or closing DC breaker/disconnect, be sure positive(+) must be connect to positive(+) and negative(-) must be connected to negative(-). Reverse polarity connection on battery will damage the inverter.

3.3.2 Function port definition

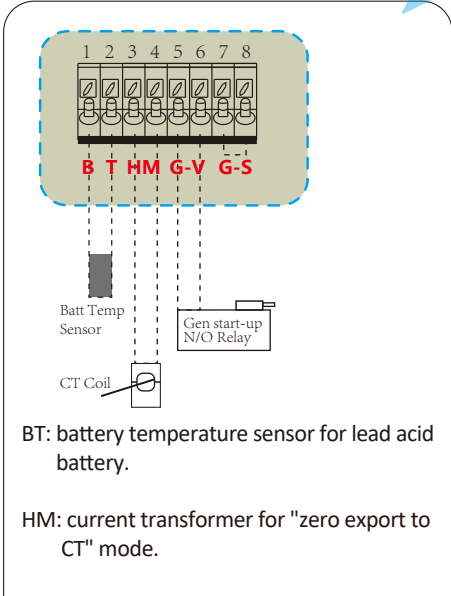
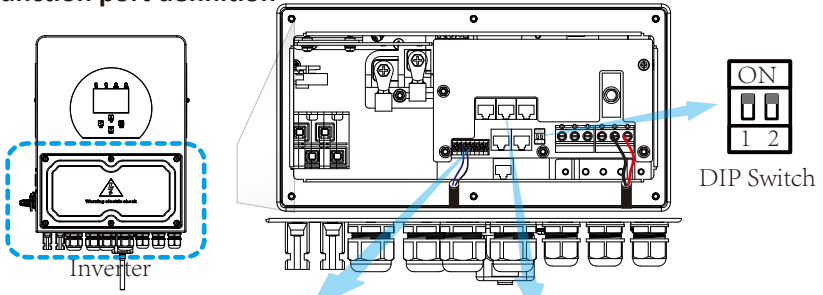

BT: battery temperature sensor for lead acid battery.

HM: current transformer for "zero export to CT" mode.

GV/GS: dry contact signal for startup the diesel generator.

When the "GEN signal" is active, the open contact (GV/GS) will switch on (no voltage output). If the "Signal ISLAND MODE" is ticked, the GS port will be the dry contact signal for startup the diesel generator. If "Signal ISLAND MODE" is not ticked, the GV port will be the dry contact signal for startup the diesel generator.

DIP switch: Parallel communication resistor
 If the number of inverters in the parallel system is less than or equal to 6, all inverter's DIP switch (1&2) need be ON position.
 If the number of inverters in parallel system exceeds 6, the main 6pcs inverter's DIP switch needs to be ON position. And the other inverter DIP switch (1&2) needs to be OFF position.

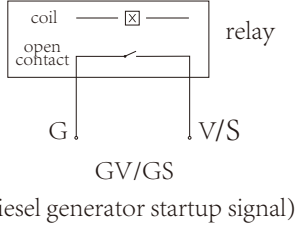
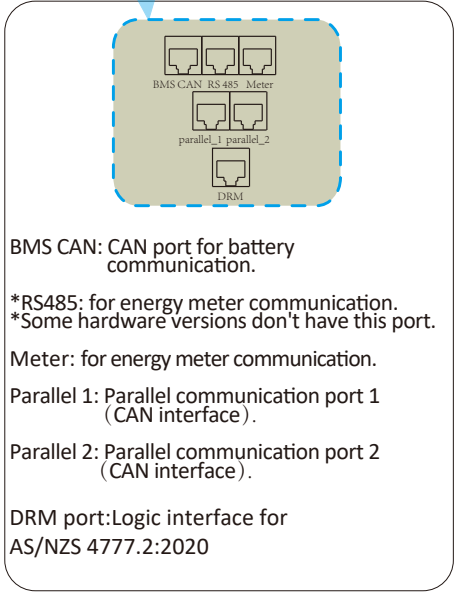

3.3.3 Temperature sensor connection for lead-acid battery

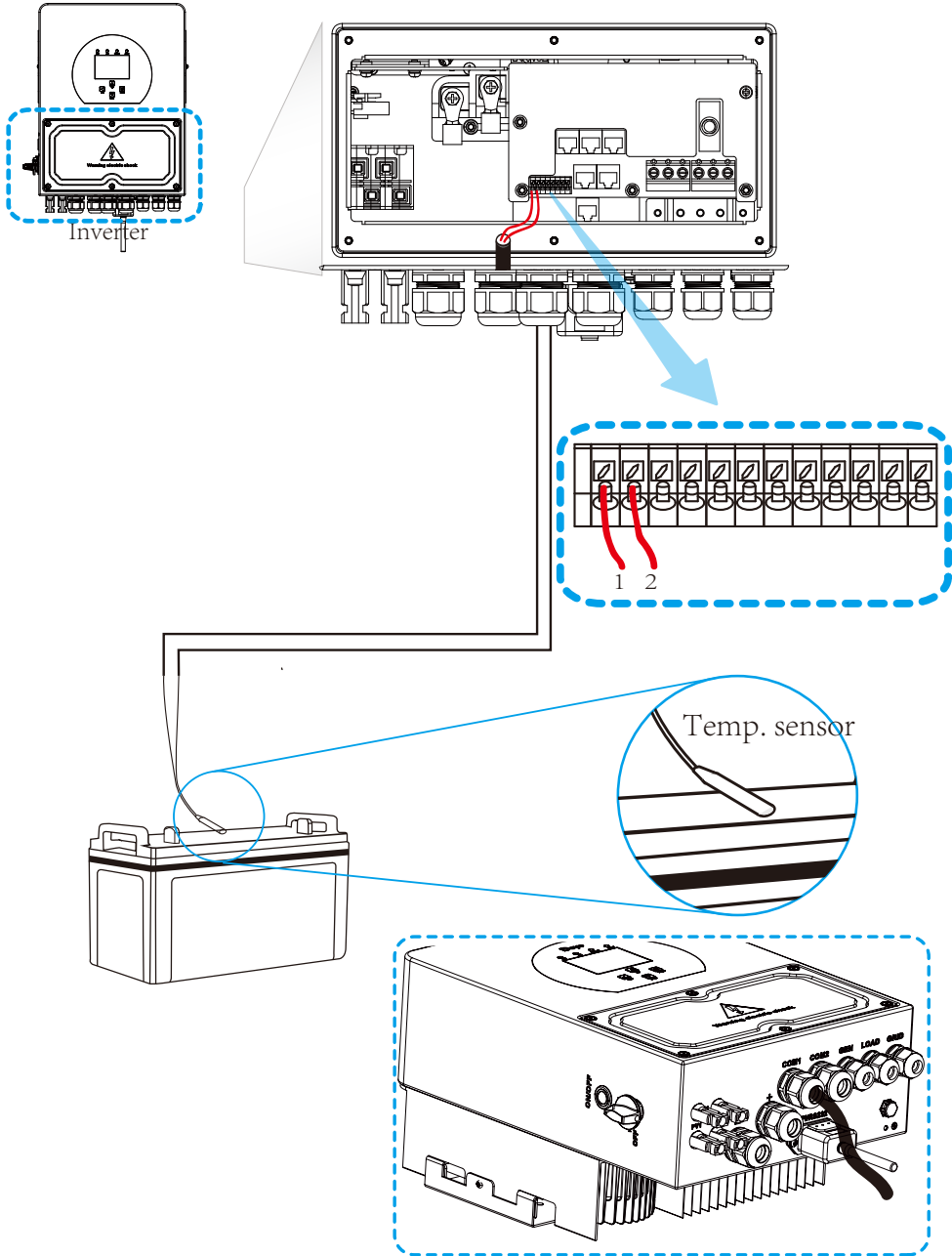

3.4 Grid connection and backup load connection

- Before connecting to grid, please install a separate AC breaker between inverter and grid. Also, it is recommended that installs an AC breaker between backup load and inverter. This will ensure the inverter can be securely disconnected during maintenance and fully protected from over current. For the 3/3.6/5/6KW model, the recommended AC breaker for backup load is 32A/40A. For the 3/3.6/5/6KW model, the recommended AC breaker for grid is 40A. In final installation, breaker certified according to AS60947.3 shall be installed with the equipment.
- There are three terminal blocks with "Grid" "Load" and "GEN" markings. Please do not misconnect input and output connectors.



All wiring must be performed by a qualified personnel. It is very important for system safety and efficient operation to use appropriate cable for AC input connection. To reduce risk of injury, please use the proper recommended cable as below.

<i>Model</i>	<i>Wire Size</i>	<i>Cable(mm²)</i>	<i>Torque value(max)</i>
3Kw	10AWG	4	1.2Nm
3.6Kw	10AWG	6	1.2Nm
5Kw	10AWG	6	1.2Nm
6Kw	8AWG	8	1.2Nm

Chart 3-3 Recommended Size for AC wires

Please follow below steps to implement AC input/output connection:

1. Before making Grid, load and Gen port connection, be sure to turn off AC breaker or disconnect first.
2. Remove insulation sleeve 10mm length, unscrew the bolts, insert the wires according to polarities indicated on the terminal block and tighten the terminal screws. Make sure the connection is complete.

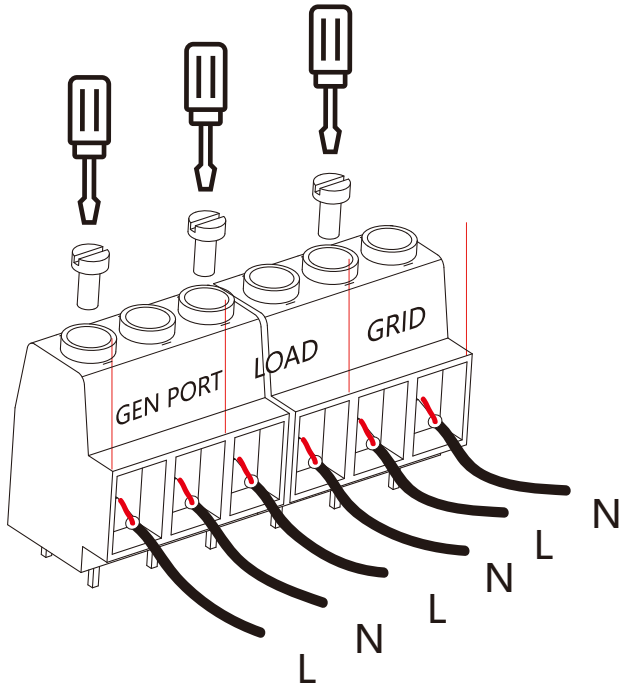
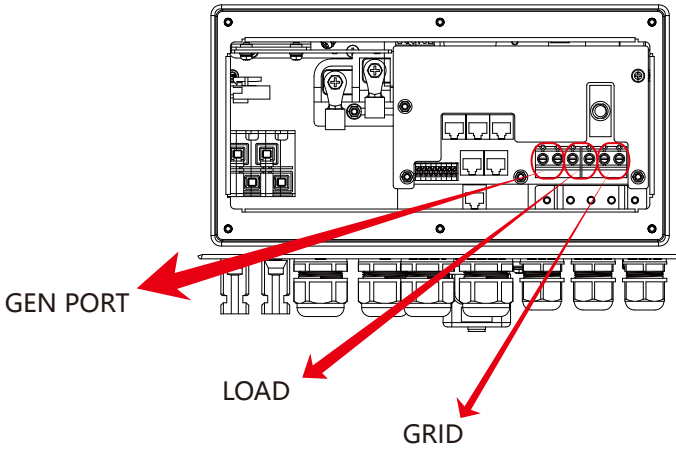



Be sure that AC power source is disconnected before attempting to wire it to the unit.

3. Then, insert AC output wires according to polarities indicated on the terminal block and tighten terminal. Be sure to connect corresponding N wires and PE wires to related terminals as well.
4. Make sure the wires are securely connected.
5. Appliances such as air conditioner are required at least 2-3 minutes to restart because it is required to have enough time to balance refrigerant gas inside of circuit. If a power shortage occurs and recovers in short time, it will cause damage to your connected appliances. To prevent this kind of damage, please check manufacturer of air conditioner if it is equipped with time-delay function before installation. Otherwise, this inverter will trigger overload fault and cut off output to protect your appliance but sometimes it still causes internal damage to the air conditioner

3.5 PV Connection

The PV modules used to connected to this inverter shall be Class A rating certified according to IEC 61730.

Before connecting to PV modules, please install a separately DC circuit breaker between inverter and PV modules. It is very important for system safety and efficient operation to use appropriate cable for PV module connection. To reduce risk of injury, please use the proper recommended cable size as below.

<i>Model</i>	<i>Wire Size</i>	<i>Cable(mm)</i>
3/3.6/5/6Kw	12AWG	4

Chart 3-4 Cable size



To avoid any malfunction, do not connect any PV modules with possible current leakage to the inverter. For example, grounded PV modules will cause current leakage to the inverter. When using PV modules, please ensure the PV+ & PV- of solar panel is not connected to the system ground bar.



It is requested to use PV junction box with surge protection. Otherwise, it will cause damage on inverter when lightning occurs on PV modules.

3.5.1 PV Module Selection:

When selecting proper PV modules, please be sure to consider below parameters:

- 1) Open circuit Voltage (Voc) of PV modules not exceeds max. PV array open circuit voltage of inverter.
- 2) Open circuit Voltage (Voc) of PV modules should be higher than min. start voltage.

<i>Inverter Model</i>	<i>3KW-SG04LP1-24</i>	<i>3KW-SG04LP1</i>	<i>3.6KW-SG04LP1</i>	<i>5KW-SG04LP1</i>	<i>6KW-SG04LP1</i>
PV Input Voltage	370V (125V~500V)				
PV Array MPPT Voltage Range	150V-425V				
No. of MPP Trackers	1		2		
No. of Strings per MPP Tracker	1	1	1+1	1+1	1+1

Chart 3-5



Note:

This inverter complies with IEC 62109-2 clause 13.9 for earth fault alarm monitoring. If an Earth Fault Alarm occurs, the inverter will not connect to the grid and will report an error F04 on its LCD. At the same time, the buzzer will sound.

3.6 CT Connection

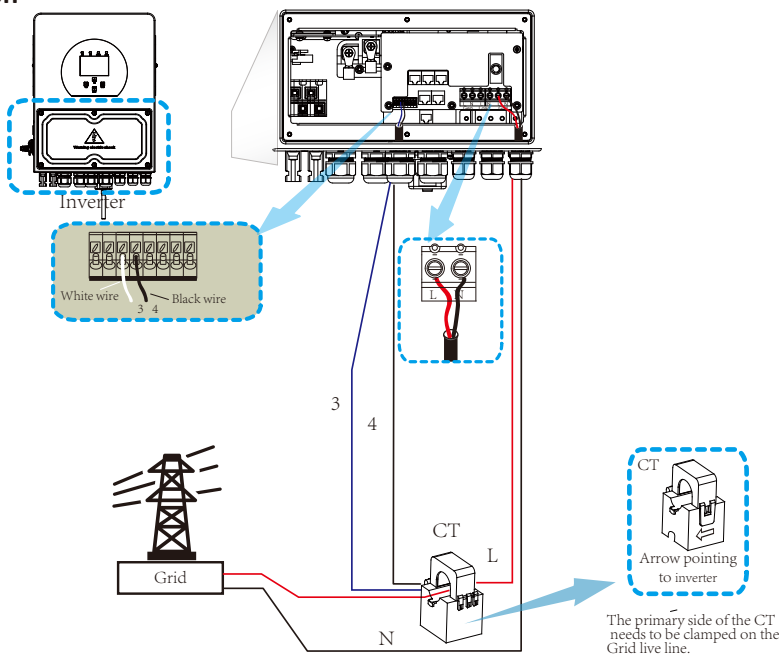

***Note:** when the reading of the load power on the LCD is not correct, please reverse the CT arrow.

3.6.1 Meter Connection

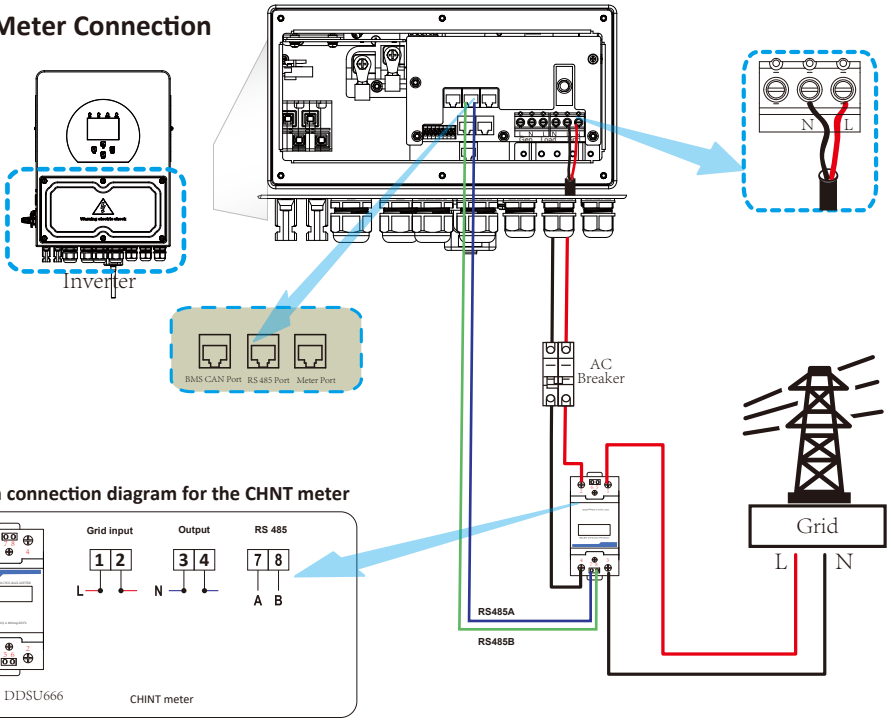

System connection diagram for the Eastron meter

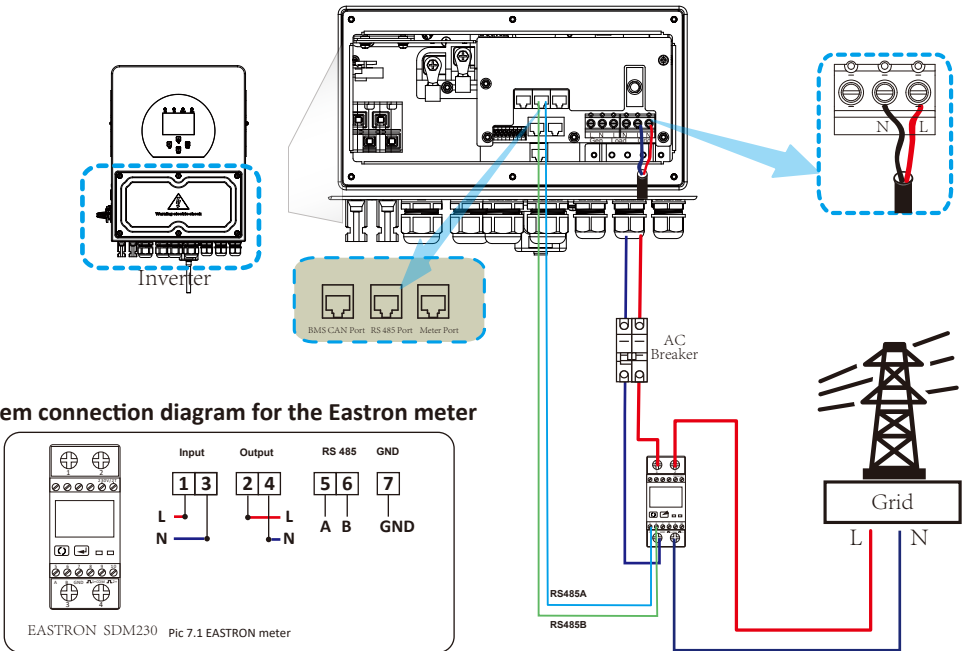



Note:

inverter has built-in leakage current detection circuit, If an external RCD is required, a type-A RCD with rated residual current of 300mA or higher is suggested. Otherwise inverter may not work properly

3.7 Earth Connection(mandatory)

Ground cable shall be connected to ground plate on grid side this prevents electric shock. if the original protective conductor fails.

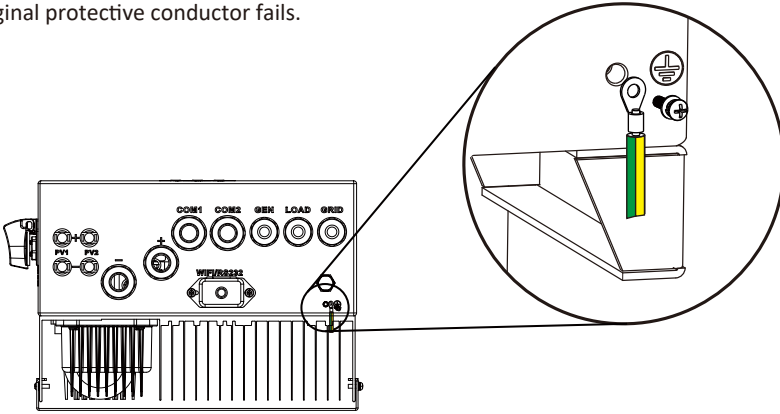

3.8 WIFI Connection

For the configuration of Wi-Fi Plug, please refer to illustrations of the Wi-Fi Plug.

3.9 Wiring System for Inverter

This diagram is an example for grid systems without special requirements on electrical wiring connection.
 Note: The back-up PE line and earthing bar must be grounded properly and effectively.
 Otherwise the back-up function may be abnormal when the grid fails.
 In final installation, breaker certified according to AS60947.3 shall be installed with the equipment.
 All circuit breakers are external components of the inverter.

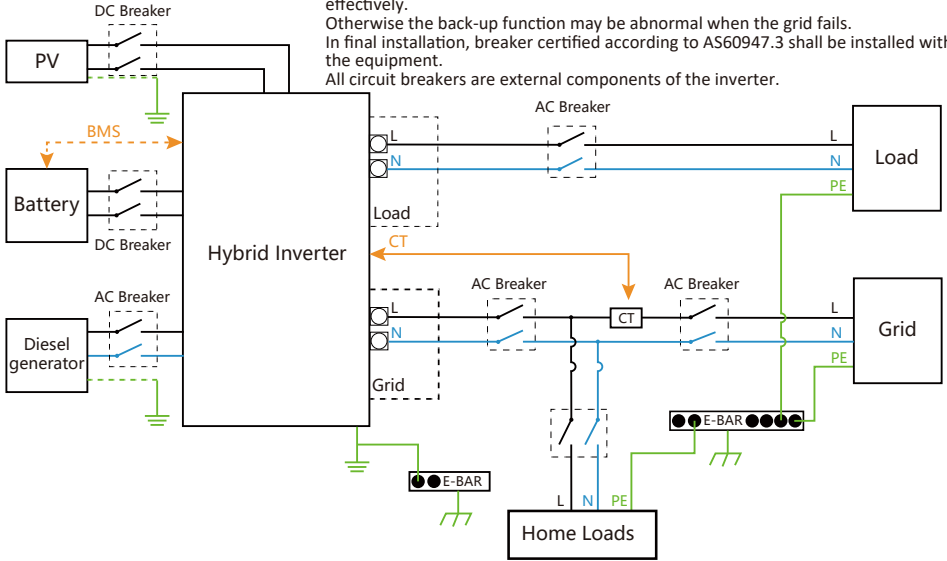

This diagram is an example for application that Neutral connects together with PE in distribution box.
 Such as: Australia, New Zealand, South Africa, etc. (Please follow local wiring regulations!)

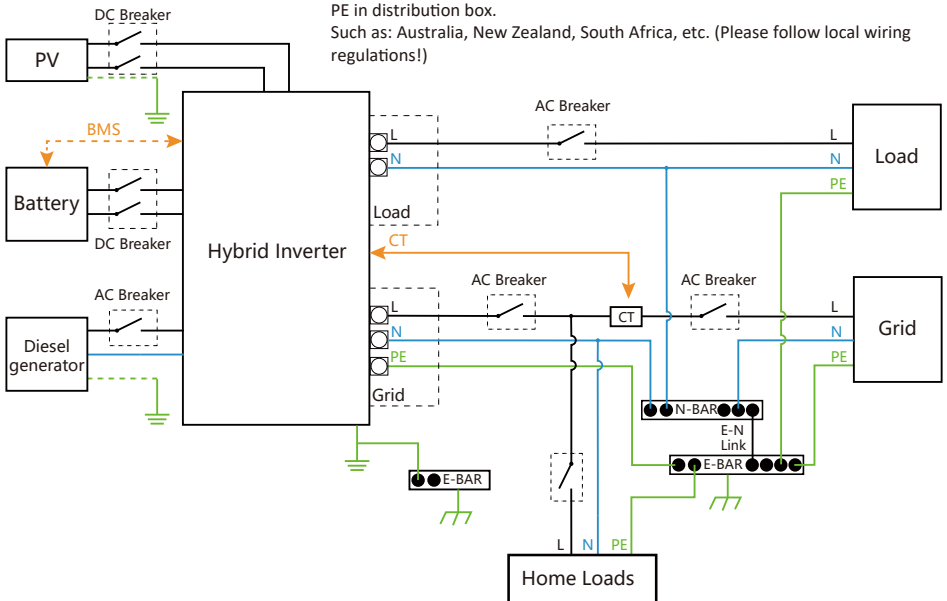

4. OPERATION

4.1 Power ON/OFF

Once the unit has been properly installed and the batteries are connected well, simply press On/Off button(located on the left side of the case) to turn on the unit. When system without battery connected, but connect with either PV or grid, and ON/OFF button is switched off, LCD will still light up(Display will show OFF), In this condition, when switch on ON/OFF button and select NO battery, system can still work.(NOTE: Choose the correct country code. (refer to section 5.8 of this manual) Notice: Different distribution network operators in different countries have different requirements regarding grid connections of PV grid connected inverters. Therefore, it's very important to make sure that you have selected the correct country code according to requirements of local authority. Please consult qualified electrical engineer or personnel from electrical safety authorities about this.)

4.2 Operation and Display Panel

The operation and display panel, shown in below chart, is on the front panel of the inverter. It includes four indicators, four function keys and a LCD display, indicating the operating status and input/output power information.

<i>LED Indicator</i>		<i>Messages</i>
DC	Green led solid light	PV Connection normal
AC	Green led solid light	Grid Connection normal
Normal	Green led solid light	Inverter operating normal
Alarm	Red led solid light	Malfunction or warning

Chart 4-1 LED indicators

<i>Function Key</i>	<i>Description</i>
Esc	To exit setting mode
Up	To go to previous selection
Down	To go to next selection
Enter	To confirm the selection

Chart 4-2 Function Buttons

5. LCD Display Icons

5.1 Main Screen

The LCD is touchscreen, below screen shows the overall information of the inverter.

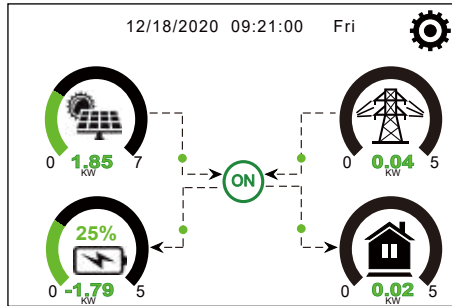

1.The icon in the center of the home screen indicates that the system is Normal operation. If it turns into "comm./FXX" , it means the inverter has communication errors or other errors, the error message will display under this icon(FXX errors, detail error info can be viewed in the System Alarms menu).

2.At the top of the screen is the time.

3.System Setup Icon, Press this set button,you can enter into the system setup screen which including Basic Setup, Battery Setup, Grid Setup, System Work Mode, Generator port use, Advanced function and Li-Batt info.

4.The main screen showing the info including Solar, Grid, Load and Battery. Its also displaying the energy flow direction by arrow. When the power is approximate to high level, the color on the panels will changing from green to red so system info showing vividly on the main screen.

- PV power and Load power always keep positive.
- Grid power negative means sell to grid, positive means get from grid.
- Battery power negative means charge, positive means discharge.

5.1.1 LCD operation flow chart

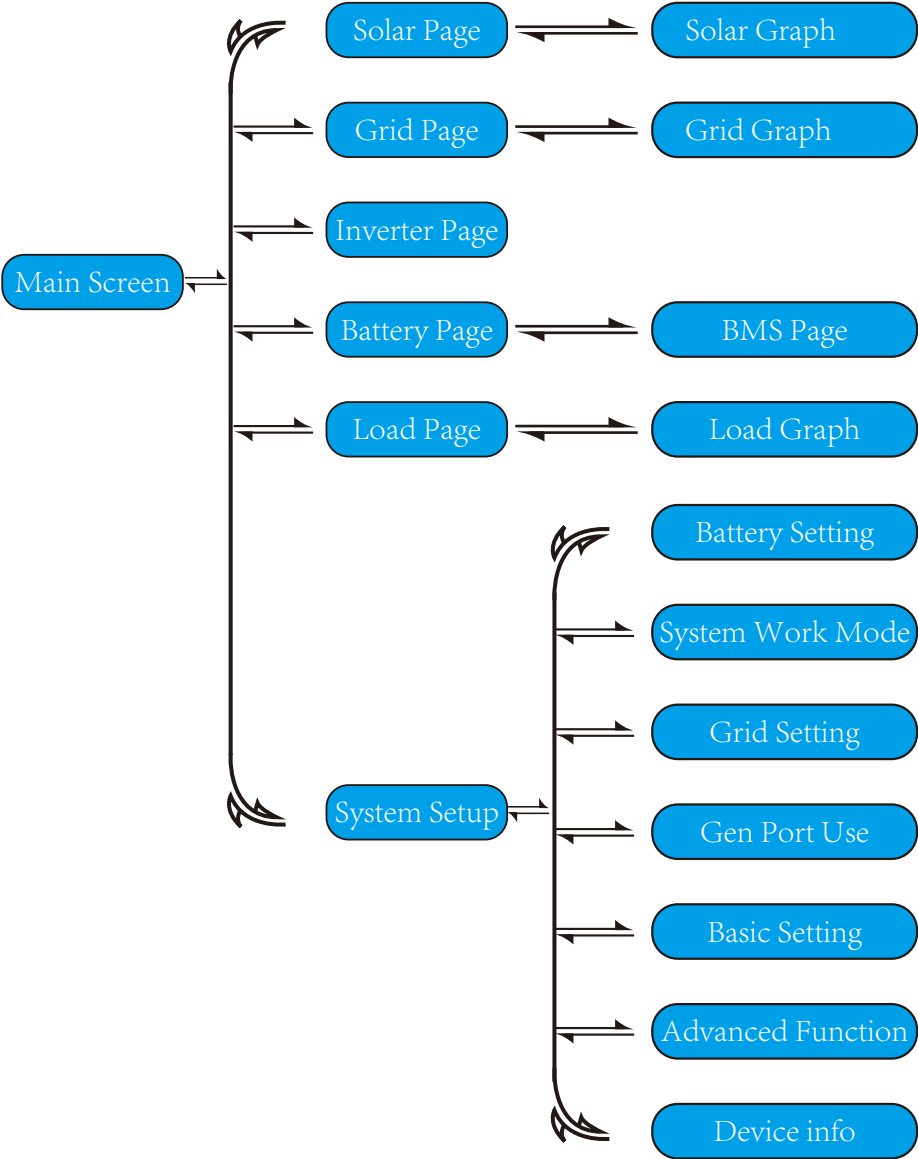

5.2 Solar Power Curve

This is Solar Panel detail page.

- ① Solar Panel Generation.
- ② Voltage, Current, Power for each MPPT.
- ③ Solar Panel energy for Day and Total.

Press the “Energy “button will enter into the power curve page.

This is Inverter detail page.

- ① Inverter Generation.
- ② Voltage, Current, Power for each Phase.
- ③ *DC-T: mean DC-DC temperature,
AC-T: mean Heat-sink temperature.
*Note: this part info is not available for some LCD FW.

This is Back-up Load detail page.

- ① Back-up Power.
- ② Voltage, Power for each Phase.
- ③ Back-up consumption for Day and Total.

Press the “Energy “ button will enter into the power curve page.

This is Grid detail page.

- ① Status, Power, Frequency.
- ② L: Voltage for each Phase
CT: Power detected by the external current sensors
LD: Power detected using internal sensors on AC grid in/out breaker
- ③ BUY: Energy from Grid to Inverter,
SELL: Energy from Inverter to grid.

Press the “Energy “ button will enter into the power curve page.

Batt

Stand-by

SOC: 36%

U:50.50V

I:-58.02A

Power: -2930W

Temp:30.0C

Li-BMS

Li-BMS

Mean Voltage:50.34V Charging Voltage :53.2V

Total Current:55.00A Discharging Voltage :47.0V

Mean Temp :23.5C Charging current :50A

Total SOC :38% Discharging current :25A

Dump Energy:57Ah

Sum Data

Details Data

Li-BMS

	Volt	Curr	Temp	SOC	Energy	Charge Volt	Charge Curr	Fault
1	50.38V	19.70A	30.6C	52.0%	25.0Ah	0.0V	0.0A	0x00
2	50.33V	18.10A	31.0C	51.0%	25.5Ah	0.0V	0.0A	0x00
3	50.30V	18.90A	30.2C	12.9%	6.0Ah	53.2V	25.0A	0x00
4	0.00V	0.00A	0.0C	0.0%	0.0Ah	0.0V	0.0A	0x00
5	0.00V	0.00A	0.0C	0.0%	0.0Ah	0.0V	0.0A	0x00
6	0.00V	0.00A	0.0C	0.9%	0.0Ah	0.0V	0.0A	0x00
7	0.00V	0.00A	0.0C	0.0%	0.0Ah	0.0V	0.0A	0x00
8	0.00V	0.00A	0.0C	0.0%	0.0Ah	0.0V	0.0A	0x00
9	0.00V	0.00A	0.0C	0.9%	0.0Ah	0.0V	0.0A	0x00
10	0.00V	0.00A	0.0C	0.0%	0.0Ah	0.0V	0.0A	0x00
11	0.00V	0.00A	0.0C	0.0%	0.0Ah	0.0V	0.0A	0x00
12	0.00V	0.00A	0.0C	0.0%	0.0Ah	0.0V	0.0A	0x00
13	0.00V	0.00A	0.0C	0.0%	0.0Ah	0.0V	0.0A	0x00
14	0.00V	0.00A	0.0C	0.0%	0.0Ah	0.0V	0.0A	0x00
15	0.00V	0.00A	0.0C	0.0%	0.0Ah	0.0V	0.0A	0x00

Sum Data

Details Data

This is Battery detail page.

if you use Lithium Battery, you can enter BMS page.

5.3 Curve Page-Solar & Load & Grid

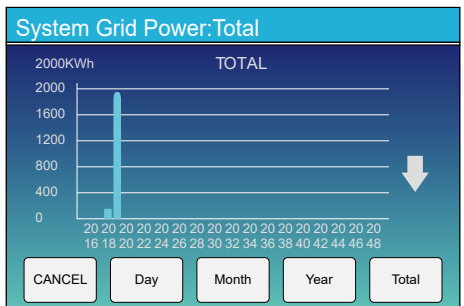
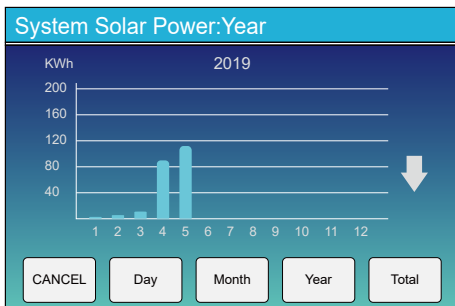
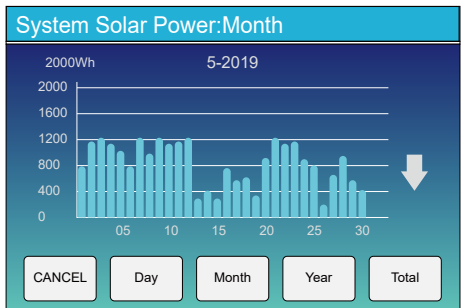
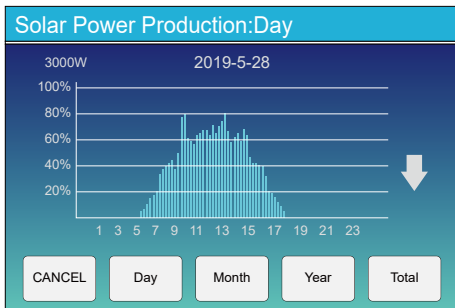

Solar power curve for daily, monthly, yearly and total can be roughly checked on the LCD, for more accuracy power generation, pls check on the monitoring system. Click the up and down arrow to check power curve of different period.

5.4 System Setup Menu

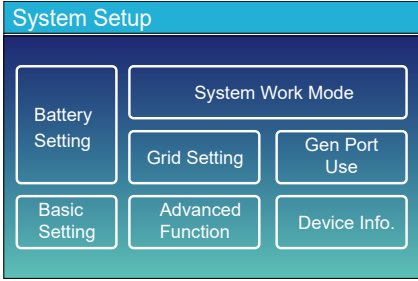

This is System Setup page.

5.5 Basic Setup Menu

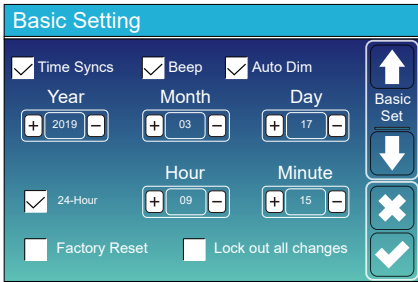

Factory Reset: Reset all parameters of the inverter.
Lock out all changes: Enable this menu for setting parameters that require locking and cannot be set up. Before performing a successful factory reset and locking the systems, to keep all changes you need to type in a password to enable the setting.

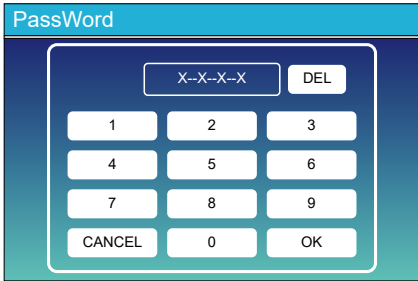

System selfchek: After ticking this item, it needs input the password.

5.6 Battery Setup Menu

Battery Setting

Batt Mode

Lithium Batt Capacity 400Ah

Use Batt V Max A Charge 40A

Use Batt % Max A Discharge 40A

No Batt Activate Battery

↑
Batt
Mode

↓

✕

✓

Battery capacity: it tells Deye hybrid inverter to know your battery bank size.

Use Batt V: Use Battery Voltage for all the settings (V).

Use Batt %: Use Battery SOC for all the settings (%).

Max. A charge/discharge: Max battery charge/discharge current(0-115A for 5KW model, 0-90A for 3.6KW model). For AGM and Flooded, we recommend Ah battery size x 20%= Charge/Discharge amps.

. For Lithium, we recommend Ah battery size x 50% = Charge/Discharge amps.

. For Gel, follow manufacturer' s instructions.

No Batt: tick this item if no battery is connected to the system.

Active battery: This feature will help recover a battery that is over discharged by slowly charging from the solar array or grid.

Battery Setting

Start 30% 30% ②

A 40A 40A

Gen Charge Grid Charge

Gen Signal Grid Signal

Gen Max Run Time 0.0 hours ③

Gen Down Time 0.5 hours

↑
Batt
Set2

↓

✕

✓

This is Battery Setup page. ① ③

Start =30%: Percent S.O.C at 30% system will AutoStart a connected generator to charge the battery bank.

A = 40A: Charge rate of 40A from the attached generator in Amps.

Gen Charge: uses the gen input of the system to charge battery bank from an attached generator.

Gen Signal: Normally open relay that closes when the Gen Start signal state is active.

Gen Max Run Time: It indicates the longest time Generator can run in one day, when time is up, the Generator will be turned off. 24H means that it does not shut down all the time.

Gen Down Time: It indicates the delay time of the Generator to shut down after it has reached the running time.

This is Grid Charge, you need select. ②

Start =30%: No use, Just for customization.

A = 40A: It indicates the Current that the Grid charges the Battery.

Grid Charge: It indicates that the grid charges the battery.

Grid Signal: Disable.

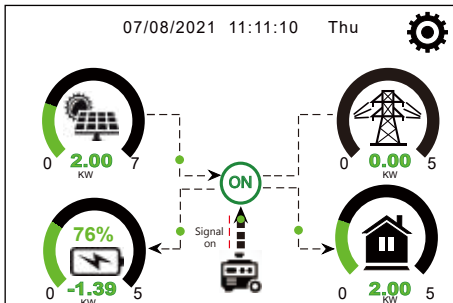

This page tells the PV and diesel generator power the load and battery.

Generator

Power: 1392W

Today=0.0 KWH

Total =2.20 KWH

L1: 228V

Freq:50.0Hz

This page tells generator output voltage, frequency, power. And, how much energy is used from generator.

Battery Setting

Lithium Mode

00

Shutdown

10%

Low Batt

20%

Restart

40%



Batt Set3



Lithium Mode: This is BMS protocol. Please reference the document (Approved Battery).

Shutdown 10%: It indicates the inverter will shutdown if the SOC below this value.

Low Batt 20%: It indicates the inverter will alarm if the SOC below this value.

Restart 40%: Battery voltage at 40% AC output will resume.

Battery Setting

Float V

53.6V

Absorption V

57.6V

Equalization V

57.6V

Equalization Days

30 days

Equalization Hours

3.0 hours

Shutdown

20%

Low Batt

35%

Restart

50%

TEMPCO(mV/C/Cell)

-5

Batt Resistance

25mOhms



Batt Set3



There are 3 stages of charging the Battery .

This is for professional installers, you can keep it if you do not know.

Shutdown 20%: The inverter will shutdown if the SOC below this value.

Low Batt 35%: The inverter will alarm if the SOC below this value.

Restart 50%: Battery SOC at 50% AC output will resume.

Recommended battery settings

Battery Type	Absorption Stage	Float Stage	Torque value (every 30 days 3hr)
AGM (or PCC)	14.2v (57.6v)	13.4v (53.6v)	14.2v(57.6v)
Gel	14.1v (56.4v)	13.5v (54.0v)	
Wet	14.7v (59.0v)	13.7v (55.0v)	14.7v(59.0v)
Lithium	Follow its BMS voltage parameters		

5.7 System Work Mode Setup Menu

System Work Mode

Selling First 5000 Max Solar Power

Zero Export To Load Solar Sell

Zero Export To CT Solar Sell

Max Sell Power: 5000 Zero-export Power: 20

Energy pattern: BattFirst LoadFirst

Grid Peak Shaving 5000 Power

↑

Work Mode1

↓

✕

✓

Work Mode

Selling First: This Mode allows hybrid inverter to sell back any excess power produced by the solar panels to the grid. If time of use is active, the battery energy also can be sold into grid. The PV energy will be used to power the load and charge the battery and then excess energy will flow to grid. Power source priority for the load is as follows:

1. Solar Panels.
2. Grid.
3. Batteries (until programable % discharge is reached).

Zero Export To Load: Hybrid inverter will only provide power to the backup load connected. The hybrid inverter will neither provide power to the home load nor sell power to grid. The built-in CT will detect power flowing back to the grid and will reduce the power of the inverter only to supply the local load and charge the battery.

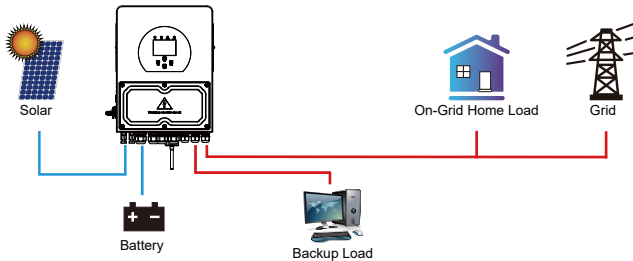

Zero Export To CT: Hybrid inverter will not only provide power to the backup load connected but also give power to the home load connected. If PV power and battery power is insufficient, it will take grid energy as supplement. The hybrid inverter will not sell power to grid. In this mode, a CT is needed. The installation method of the CT please refer to chapter 3.6 CT Connection. The external CT will detect power flowing back to the grid and will reduce the power of the inverter only to supply the local load, charge battery and home load.

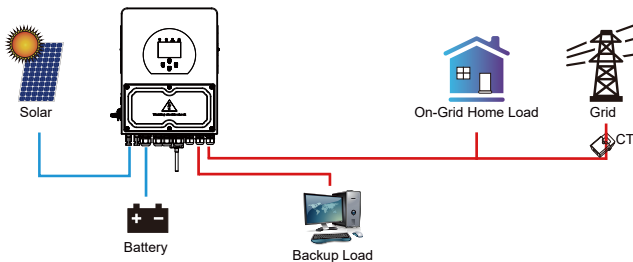

Note:

Customer can only use export limit control function by CT or meter.

Solar Sell: "Solar sell" is for Zero export to load or Zero export to CT: when this item is active, the surplus energy can be sold back to grid. When it is active, PV Power source priority usage is as follows: load consumption and charge battery and feed into grid.

Max. sell power: Allowed the maximum output power to flow to grid.

Zero-export Power: for zero-export mode, it tells the grid output power. Recommend to set it as 20-100W to ensure the hybrid inverter won't feed power to grid.

Energy Pattern: PV Power source priority.

Batt First: PV power is firstly used to charge the battery and then used to power the load. If PV power is insufficient, grid will make supplement for battery and load simultaneously.

Load First: PV power is firstly used to power the load and then used to charge the battery. If PV power is insufficient, grid will make supplement for battery and load simultaneously.

Max Solar Power: will allow the maximum DC input power.

Grid Peak-shaving: when it is active, grid output power will be limited within the set value. If the load power exceeds the allowed value, it will take PV energy and battery as supplement. If still can't meet the load requirement, grid power will increase to meet the load needs.

System Work Mode						
Grid Charge	Gen	Time Of Use		Power	Batt	Work Mode2
		Time	Power			
<input type="checkbox"/>	<input type="checkbox"/>	01:00	5:00	5000	49.0V	<input type="checkbox"/> ↑ <input type="checkbox"/> ↓ <input checked="" type="checkbox"/> ✕ <input checked="" type="checkbox"/> ✓
<input type="checkbox"/>	<input type="checkbox"/>	05:00	9:00	5000	50.2V	
<input checked="" type="checkbox"/>	<input type="checkbox"/>	09:00	13:00	5000	50.9V	
<input checked="" type="checkbox"/>	<input type="checkbox"/>	13:00	17:00	5000	51.4V	
<input checked="" type="checkbox"/>	<input type="checkbox"/>	17:00	21:00	5000	47.1V	
<input checked="" type="checkbox"/>	<input type="checkbox"/>	21:00	01:00	5000	49.0V	

Time of use: it is used to program when to use grid or generator to charge the battery, and when to discharge the battery to power the load. Only tick "Time Of Use" then the follow items (Grid, charge, time, power etc.) will take effect.

Note: when in selling first mode and click time of use, the battery power can be sold into grid.

Grid charge: utilize grid to charge the battery in a time period.

Gen charge: utilize diesel generator to charge the battery in a time period.

Time: real time, range of 01:00-24:00.

Power: Max. discharge power of battery allowed.

Batt(V or SOC %): battery SOC % or voltage at when the action is to happen.

For example:

During 01:00-05:00, when battery SOC is lower than 80%, it will use grid to charge the battery until battery SOC reaches 80%.

During 05:00-08:00 and 08:00-10:00, when battery SOC is higher than 40%, hybrid inverter will discharge the battery until the SOC reaches 40%.

During 10:00-15:00, when battery SOC is higher than 80%, hybrid inverter will discharge the battery until the SOC reaches 80%.

During 15:00-18:00, when battery SOC is higher than 40%, hybrid inverter will discharge the battery until the SOC reaches 40%.

During 18:00-01:00, when battery SOC is higher than 35%, hybrid inverter will discharge the battery until the SOC reaches 35%.

System Work Mode						
Grid Charge	Gen	Time Of Use		Power	Batt	Work Mode2
		Time	Power			
<input checked="" type="checkbox"/>	<input type="checkbox"/>	01:00	5:00	5000	80%	<input type="checkbox"/> ↑ <input type="checkbox"/> ↓ <input type="checkbox"/> ✕ <input checked="" type="checkbox"/> ✓
<input type="checkbox"/>	<input type="checkbox"/>	05:00	8:00	5000	40%	
<input type="checkbox"/>	<input type="checkbox"/>	08:00	10:00	5000	40%	
<input type="checkbox"/>	<input type="checkbox"/>	10:00	15:00	5000	80%	
<input type="checkbox"/>	<input type="checkbox"/>	15:00	18:00	5000	40%	
<input type="checkbox"/>	<input type="checkbox"/>	18:00	01:00	5000	35%	

5.8 Grid Setup Menu

5.8.1 Commissioning Procedure

If all physical connection is checked ok, please follow the steps below.

1. Turn on AC circuit breaker.
2. Turn on DC circuit breaker on PV strings and battery.
3. Turn on circuit breaker on battery pack.
4. Turn on DC switch on the inverter
5. Check the inverter status by inverter indicators and battery status by battery indicators.



Note:

Inverters cannot be installed in multiple combinations.

5.8.2 Grid Standard Selection

Grid Setting/Grid code selection

Grid Mode: General Standard 0/11

Grid Frequency: 50HZ 60HZ

Phase Type: 0/120/240 0/240/120

Grid Level: LN:220VAC LL:380VAC

IT system-neutral is not grounded

Grid Set1

↓

✕

✓

Grid Mode: General Standard、UL1741 & IEEE1547、CPUC RULE21、SRD-UL-1741、CEI 0-21、AS4777_A、AS4777_B、AS4777_C、EN50549_CZ-PPDS(>16A)、NewZealand、VDE4105、OVE-Directive R25.
Please follow the local grid code and then choose the corresponding grid standard.

Grid level: there're several voltage levels for the inverter output voltage when it is in off-grid mode.
LN:230VAC LL:400VAC, LN:240VAC LL:420VAC, LN:120VAC LL:208VAC, LN:133VAC LL:230VAC.

IT system: For the IT grid system, the Line voltage

(between any two lines in a three-phase circuit) is 230Vac, and the diagram is as follow. If your grid system is IT system, please enable "IT system" and tick the "Grid level" as 133-3P as below picture shows.

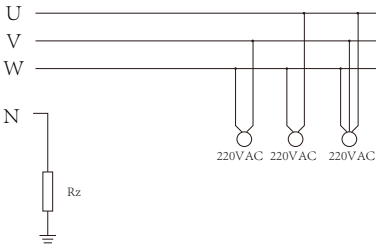

Rz: Large resistance ground resistor. Or the system doesn't have Neutral line

For The Australian Market:

For compliance with AS/NZS 4777.2:2020 please select from

- Australia A • Australia B • Australia C • New Zealand

Please contact your local grid operator for which option to select

Note: By selecting Australia A, Australia B or Australia C the power quality response mode and grid protection settings will be reset to their default values for Australia RegionA, B, C respectively.

Default volt-watt settings for different regions are shown in the following table:

Region	Default value	V_{W1}	V_{W1-ch}	V_{W2}	V_{W2-ch}
Australia A	Voltage	253V	207V	260V	215V
	Inverter maximum active power output level(P) % of S_{rated}	100%	20%	20%	100%
Australia B	Voltage	250V	195V	260V	215V
	Inverter maximum active power output level(P) % of S_{rated}	100%	0%	20%	100%
Australia C	Voltage	253V	207V	260V	215V
	Inverter maximum active power output level(P) % of S_{rated}	100%	20%	20%	100%
New Zealand	Voltage	242V	216V	250V	224V
	Inverter maximum active power output level(P) % of S_{rated}	100%	20%	20%	100%

Default volt-var settings for different regions are shown in the following table:

Region	Default value	Vv ₁	Vv ₂	Vv ₃	Vv ₄
Australia A	Voltage	207V	220V	240V	258V
	Inverter maximum active power output level(P) % of S _{rated}	44%supplying	0%	0%	60%absorbing
Australia B	Voltage	205V	220V	235V	255V
	Inverter maximum active power output level(P) % of S _{rated}	30%supplying	0%	0%	40%supplying
Australia C	Voltage	215V	230V	240V	255V
	Inverter maximum active power output level(P) % of S _{rated}	44%supplying	0%	0%	60%supplying
New Zealand	Voltage	207V	220V	235V	244V
	Inverter maximum active power output level(P) % of S _{rated}	60%supplying	0%	0%	60%supplying

Grid Setting/Connect

Normal connect	Normal Ramp rate	10s	
Low frequency	48.00Hz	High frequency	51.50Hz
Low voltage	185.0V	High voltage	265.0V
Reconnect after trip	Reconnect Ramp rate	36s	
Low frequency	48.20Hz	High frequency	51.30Hz
Low voltage	187.0V	High voltage	263.0V
Reconnection Time	60s	PF	1.000

Normal connect: The allowed grid voltage/frequency range when the inverter first time connect to the grid.
Normal Ramp rate: It is the startup power ramp.

Reconnect after trip: The allowed grid voltage /frequency range for the inverter connects the grid after the inverter trip from the grid.

Reconnect Ramp rate:It is the reconnection power ramp.

Reconnection time: The waiting time period for the inverter connects the grid again

PF: Power factor which is used to adjust inverter reactive power

Grid Setting/IP Protection

Over voltage U>(10 min. running mean)		260.0V	
HV3		HF3	
HV2	287.5V -- 0.10s	HF2	52.00Hz -- 0.10s
HV1	253.0V -- 0.10s	HF1	51.50Hz -- 0.10s
LV1	195.5V -- 0.10s	LF1	47.50Hz -- 0.10s
LV2	92.0V -- 0.10s	LF2	47.00Hz -- 0.10s
LV3		LF3	

HV1: Level 1 overvoltage protection point;
HV2: Level 2 overvoltage protection point; ② 0.1s—Trip time.
HV3: Level 3 overvoltage protection point.

LV1: Level 1 undervoltage protection point;
LV2: Level 2 undervoltage protection point;
LV3: Level 3 undervoltage protection point.

HF1: Level 1 over frequency protection point;
HF2: Level 2 over frequency protection point;
HF3: Level 3 over frequency protection point.

LF1: Level 1 under frequency protection point;
LF2: Level 2 under frequency protection point;
LF3: Level 3 under frequency protection point.

Grid Setting/F(W)

F(W)			
Over frequency	Droop F	40%P/Hz	
Start freq F	50.20Hz	Stop freq F	51.5Hz
Start delay F	0.00s	Stop delay F	0.00s
Under frequency	Droop F	40%PE/Hz	
Start freq F	49.80Hz	Stop freq F	49.80Hz
Start delay F	0.00s	Stop delay F	0.00s

FW: this series inverter is able to adjust inverter output power according to grid frequency.

Drkoop f: percentage of nominal power per Hz
 For example, "Start freq > 50.2Hz, Stop freq f < 51.5, Droop f=40%P/Hz" when the grid frequency reaches 50.2Hz, the inverter will decrease its active power at Droop f of 40%. And then when grid system frequency is less than 50.1Hz, the inverter will stop decreasing output power.

For the detailed setup values, please follow the local grid code.

Grid Setting/V(W) V(Q)

<input type="checkbox"/> V(W)		<input type="checkbox"/> V(Q)		<input type="button" value="↑"/> Grid Set5 <input type="button" value="↓"/> <input type="button" value="✕"/> <input type="button" value="✓"/>
V1	108.0%	P1	100%	
V2	110.0%	P2	80%	
V3	112.0%	P3	60%	
V4	114.0%	P4	40%	
Lock-in/Pn		Lock-out/Pn		
V1	94.0%	Q1	44%	
V2	97.0%	Q2	0%	
V3	105.0%	Q3	0%	
V4	108.0%	Q4	-44%	

V(W): It is used to adjust the inverter active power according to the set grid voltage.

V(Q): It is used to adjust the inverter reactive power according to the set grid voltage.

This function is used to adjust inverter output power (active power and reactive power) when grid voltage changes.

%Un: % of rated voltage.

%Invert: % of rated power.

For example: V2=110%, P2=80%. When the grid voltage reaches the 110% times of rated grid voltage, inverter output power will reduce its active output power to 80% rated power.

For example: V1=94%, Q1=44%. When the grid voltage reaches the 94% times of rated grid voltage, inverter output power will output 44% reactive output power.

For the detailed setup values, please follow the local grid code.

Grid Setting/P(Q) P(PF)

<input type="checkbox"/> P(Q)		<input type="checkbox"/> P(PF)		<input type="button" value="↑"/> Grid Set6 <input type="button" value="↓"/> <input type="button" value="✕"/> <input type="button" value="✓"/>
P1	0%	Q1	2%	
P2	2%	Q2	0%	
P3	0%	Q3	21%	
P4	22%	Q4	25%	
Lock-in/Pn		Lock-out/Pn		
P1	0%	PF1	-0.000	
P2	0%	PF2	-0.000	
P3	0%	PF3	0.000	
P4	62%	PF4	0.264	

PQ: It is used to adjust the inverter reactive power according to the set active power.

P(PF): It is used to adjust the inverter PF according to the set active power.

For the detailed setup values, please follow the local grid code.

Grid Setting/LV(RT)

<input type="checkbox"/> L/HVR		<input type="button" value="↑"/> Grid Set7 <input type="button" value="↓"/> <input type="button" value="✕"/> <input type="button" value="✓"/>
HV1	0.0V	
LV1	0.0V	

Reserved: This function is reserved.

Basic Setting

<input type="checkbox"/> Time Syncs	<input type="checkbox"/> Beep	<input checked="" type="checkbox"/> Auto Dim	<input type="button" value="↑"/> Basic Set <input type="button" value="↓"/> <input type="button" value="✕"/> <input type="button" value="✓"/>
Year	Month	Day	
<input type="button" value="+"/> 2019 <input type="button" value="-"/>	<input type="button" value="+"/> 03 <input type="button" value="-"/>	<input type="button" value="+"/> 17 <input type="button" value="-"/>	
Hour	Minute		
<input type="checkbox"/> 24-Hour	<input type="button" value="+"/> 09 <input type="button" value="-"/>	<input type="button" value="+"/> 15 <input type="button" value="-"/>	
<input type="checkbox"/> Factory Reset	<input checked="" type="checkbox"/> Lock out all changes		

After setting grid parameters, please select "Lock out all changes" and enter password. If the engineer does not know the password, please contact your distributor or Deye.

5.8.2 Grid Parameter Check

After steps above, customers can see firmware version on main page grid parameters in grid settings on LCD.

5.9 Generator Port Use Setup Menu

GEN PORT USE

Mode

Generator Input
Rated Power: 8000W

AC couple on grid side
 AC couple on load side

GEN connect to Grid input

SmartLoad Output
Power: 500W
AC Couple Fre High: 52.00Hz

On Grid always on

Micro Inv Input
OFF: 95%
ON: 100%

↑
PORT Set1

↓

✕

✓

Generator input rated power: allowed Max. power from diesel generator.

GEN connect to grid input: connect the diesel generator to the grid input port.

Smart Load Output: This mode utilizes the Gen input connection as an output which only receives power when the battery SOC and PV power is above a user programmable threshold.
e.g. **Power=500W, ON: 100%, OFF=95%:** When the PV power exceeds 500W, and battery bank SOC reaches 100%, Smart Load Port will switch on automatically and power the load connected. When the battery bank SOC < 95% or PV power < 500w, the Smart Load Port will switch off automatically.

Smart Load OFF Batt

- Battery SOC at which the Smart load will switch off.

Smart Load ON Batt

- Battery SOC at which the Smart load will switch on. Also, the PV input power should exceed the setting value (Power) simultaneously and then the Smart load will switch on.

On Grid always on: When click "on Grid always on" the smart load will switch on when the grid is present.

Micro Inv Input: To use the Generator input port as a micro-inverter on grid inverter input (AC coupled), this feature will also work with "Grid-Tied" inverters.

- * Micro Inv Input OFF: when the battery SOC exceeds setting value, Microinverter or grid-tied inverter will shut down.
- * Micro Inv Input ON: when the battery SOC is lower than setting value, Microinverter or grid-tied inverter will start to work.

AC Couple Fre High: If choosing "Micro Inv input", as the battery SOC reaches gradually setting value (OFF), During the process, the microinverter output power will decrease linear. When the battery SOC equals to the setting value (OFF), the system frequency will become the setting value (AC couple Fre high) and the Microinverter will stop working.

* **MI export to grid cutoff:** Stop exporting power produced by the microinverter to the grid.

* Note: Micro Inv Input OFF and On is valid for some certain FW version only.

* AC couple on load side: connecting the output of on-grid inverter at the load port of the hybrid inverter. In this situation, the hybrid inverter will not be able to show the load power correctly.

* AC couple on grid side: this function is reserved.

* Note: Some firmware versions don't have this function.

5.10 Advanced Function Setup Menu

Advanced Function

Solar Arc Fault ON
Backup Delay: 0S

Clear Arc_Fault

System selfcheck
 Gen peak-shaving

DRM
CT Ratio: 2000: 1

Signal ISLAND MODE

BMS_Err_Stop

↑
Func Set1

↓

✕

✓

Solar Arc Fault ON: This is only for US.

System selfcheck: Disable. this is only for factory.

Gen Peak-shaving: Enable When the power of the generator exceeds the rated value of it, the inverter will provide the redundant part to ensure that the generator will not overload.

DRM: For AS4777 standard

Backup Delay: Reserved

BMS_Err_Stop: When it is active, if the battery BMS failed to communicate with inverter, the inverter will stop working and report fault.

Signal island mode: when the inverter connects grid, the ATS port will output 230Vac and it is used to cut off Earth-Neutral(load port N line) bond via connect external relay. When the inverter disconnects from the grid, ATS port voltage will be 0 and the Earth-Neutral bond keeps on. More details, please refer to left picture.

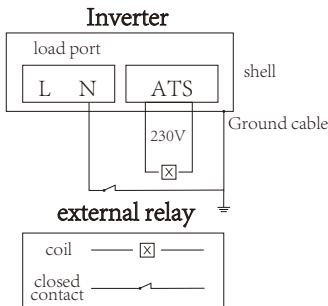

Advanced Function

Parallel Modbus SN A Phase
 Master B Phase
 Slave C Phase

Ex_Meter For CT
 A Phase
 B Phase
 C Phase



Ex_Meter For CT: when in Three phase system with CHNT Three phase energy meter (DTSU666), click corresponding phase where hybrid inverter is connected. e.g. when the hybrid inverter output connects to A phase, please click A Phase.

5.11 Device Info Setup Menu

Device Info.

Inverter ID: 1601012001 Flash
 HMI: Ver0302 MAIN:Ver2138

Alarms Code	Occurred
F64 Heatsink_HighTemp_Fault	2019-03-11 15:56
F64 Heatsink_HighTemp_Fault	2019-03-08 10:46
F64 Heatsink_HighTemp_Fault	2019-03-08 10:45



This page show Inverter ID, Inverter version and alarm codes.

HMI: LCD version

MAIN: Control board FW version

6. Mode

Mode I: Basic

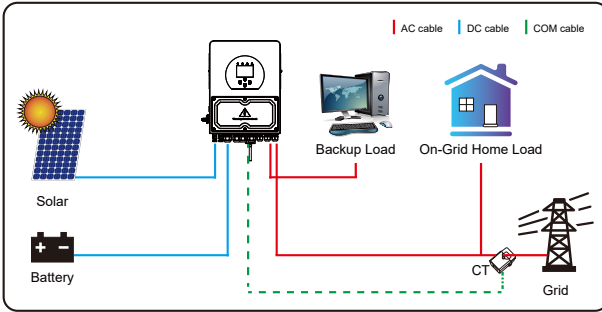

Mode II: With Generator

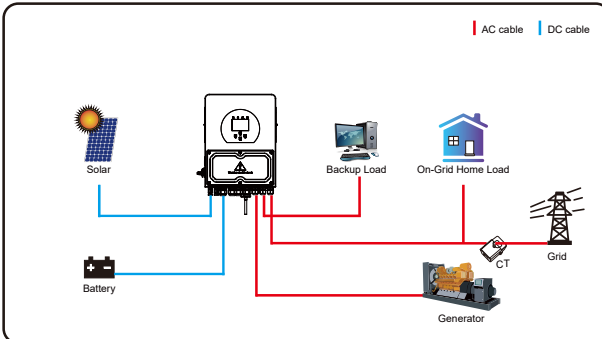

Mode III: With Smart-Load

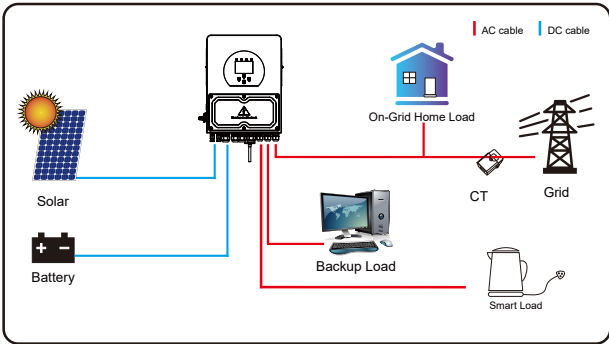

Mode IV: AC Couple

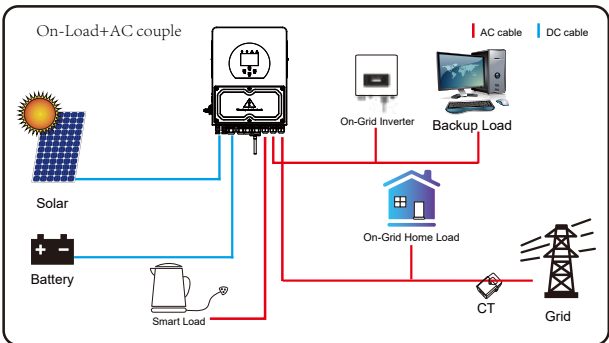
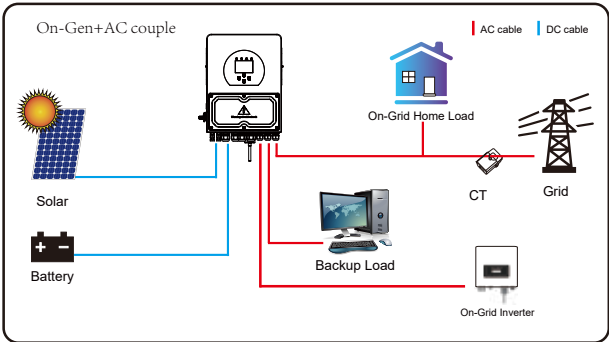

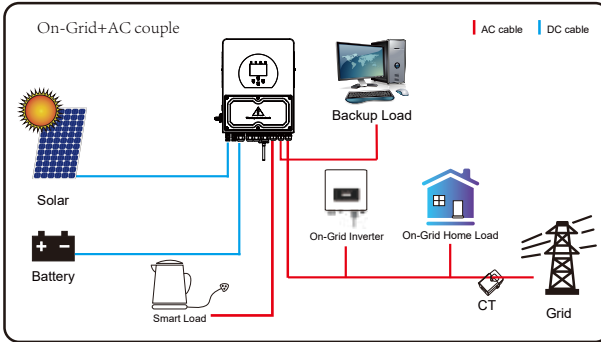

The 1st priority power of the system is always the PV power, then 2nd and 3rd priority power will be the battery bank or grid according to the settings. The last power backup will be the Generator if it is available.

7. Fault information and processing

The energy storage inverter is designed according to the grid-connected operation standard and meets the safety requirements and electromagnetic compatibility requirements. Before leaving the factory, the inverter undergoes several rigorous tests to ensure that the inverter can operate reliably.



If any of the fault messages listed in Table 6-1 appear on your inverter and the fault has not been removed after restarting, please contact your local dealer or service center. You need to have the following information ready.

1. Inverter serial number;
2. Distributor or service center of the inverter ;
3. On-grid power generation date;
4. The problem description (including the fault code and indicator status displayed on the LCD) is as detailed as possible.
5. Your contact information. In order to give you a clearer understanding of the inverter's fault information, we will list all possible fault codes and their descriptions when the inverter is not working properly.

Error code	Description	Solutions
F08	GFDI_Relay_Failure	<ol style="list-style-type: none"> 1. When inverter is in Split phase(120/240Vac) or three-phase system (120/208Vac) system, the backup load port N line needs to connect ground; 2. If the fault still exists, please contact us for help.
F13	Working mode change	<ol style="list-style-type: none"> 1. When the grid type and frequency changed it will report F13; 2. When the battery mode was changed to "No battery" mode, it will report F13; 3. For some old FW version, it will report F13 when the system work mode changed; 4. Generally, it will disappear automatically when shows F13; 5. If still same, and turn off the DC switch and AC switch and wait for one minute and then turn on the DC/AC switch; 6. Seek help from us, if can not go back to normal state.
F18	AC over current fault of hardware	<p>AC side over current fault</p> <ol style="list-style-type: none"> 1. Please check whether the backup load power and common load power are within the range; 2. Restart and check whether it is in normal; 3. Seek help from us, if can not go back to normal state.
F20	DC over current fault of the hardware	<p>DC side over current fault</p> <ol style="list-style-type: none"> 1. Check PV module connect and battery connect; 2. When in the off-grid mode, the inverter startup with big power load, it may report F20. Please reduce the load power connected; 3. Turn off the DC switch and AC switch and then wait one minute, then turn on the DC/AC switch again; 4. Seek help from us, if can not go back to normal state.
F22	Tz_EmergStop_Fault	Please contact your installer for help.
F23	AC leakage current is transient over current	<p>Leakage current fault</p> <ol style="list-style-type: none"> 1. Check PV side cable ground connection. 2. Restart the system 2~3 times. 3. If the fault still exists, please contact us for help.
F24	DC insulation impedance failure	<p>PV isolation resistance is too low</p> <ol style="list-style-type: none"> 1. Check the connection of PV panels and inverter is firmly and correctly; 2. Check whether the PE cable of inverter is connected to ground; 3. Seek help from us, if can not go back to normal state.
F26	The DC busbar is unbalanced	<ol style="list-style-type: none"> 1. Please wait for a while and check whether it is normal; 2. When the hybrid in split phase mode, and the load of L1 and load of L2 is big different, it will report the F26. 3. Restart the system 2~3 times. 4. Seek help from us, if can not go back to normal state.
F29	Parallel CANBus fault	<ol style="list-style-type: none"> 1. When in parallel mode, check the parallel communication cable connection and hybrid inverter communication address setting; 2. During the parallel system startup period, inverters will report F29. when all inverters are in ON status, it will disappear automatically; 3. If the fault still exists, please contact us for help.

Error code	Description	Solutions
F34	ACOvercurrent fault	<ol style="list-style-type: none"> 1. Check the backup load connected, make sure it is in allowed power range; 2. If the fault still exists, please contact us for help.
F35	No AC grid	<p>No Utility</p> <ol style="list-style-type: none"> 1. Please confirm grid is lost or not; 2. Check the grid connection is good or not; 3. Check the switch between inverter and grid is on or not; 4. Seek help from us, if can not go back to normal state.
F41	Parallel system stop	<ol style="list-style-type: none"> 1. Check the hybrid inverter working status. If there's 1 pcs hybrid inverter is in OFF status, the other hybrid inverters may report F41 fault in parallel system. 2. If the fault still exists, please contact us for help.
F42	AC line low voltage	<p>Grid voltage fault</p> <ol style="list-style-type: none"> 1. Check the AC voltage is in the range of standard voltage in specification; 2. Check whether grid AC cables are firmly and correctly connected; 3. Seek help from us, if can not go back to normal state.
F47	AC over frequency	<p>Grid frequency out of range</p> <ol style="list-style-type: none"> 1. Check the frequency is in the range of specification or not; 2. Check whether AC cables are firmly and correctly connected; 3. Seek help from us, if can not go back to normal state.
F48	AC lower frequency	<p>Grid frequency out of range</p> <ol style="list-style-type: none"> 1. Check the frequency is in the range of specification or not; 2. Check whether AC cables are firmly and correctly connected; 3. Seek help from us, if can not go back to normal state.
F56	DC busbar voltage is too low	<p>Battery voltage low</p> <ol style="list-style-type: none"> 1. Check whether battery voltage is too low; 2. If the battery voltage is too low, using PV or grid to charge the battery; 3. Seek help from us, if can not go back to normal state.
F58	BMS communication fault	<ol style="list-style-type: none"> 1. it tells the communication between hybrid inverter and battery BMS disconnected when "BMS_Err-Stop" is active; 2. if don't want to see this happen, you can disable "BMS_Err-Stop" item on the LCD; 3. If the fault still exists, please contact us for help.
F63	ARC fault	<ol style="list-style-type: none"> 1. ARC fault detection is only for US market; 2. Check PV module cable connection and clear the fault; 3. Seek help from us, if can not go back to normal state.
F64	Heat sink high temperature failure	<p>Heat sink temperature is too high</p> <ol style="list-style-type: none"> 1. Check whether the work environment temperature is too high; 2. Turn off the inverter for 10mins and restart; 3. Seek help from us, if can not go back to normal state.

Chart 7-1 Fault information

Under the guidance of our company, customers return our products so that our company can provide service of maintenance or replacement of products of the same value. Customers need to pay the necessary freight and other related costs. Any replacement or repair of the product will cover the remaining warranty period of the product. If any part of the product or product is replaced by the company itself during the warranty period, all rights and interests of the replacement product or component belong to the company.

Factory warranty does not include damage due to the following reasons:

- Damage during transportation of equipment ;
- Damage caused by incorrect installation or commissioning ;
- Damage caused by failure to comply with operation instructions, installation instructions or maintenance instructions ;
- Damage caused by attempts to modify, alter or repair products ;
- Damage caused by incorrect use or operation ;
- Damage caused by insufficient ventilation of equipment ;
- Damage caused by failure to comply with applicable safety standards or regulations ;
- Damage caused by natural disasters or force majeure (e.g. floods, lightning, overvoltage, storms, fires, etc.)

In addition, normal wear or any other failure will not affect the basic operation of the product. Any external scratches, stains or natural mechanical wear does not represent a defect in the product.

8.Limitation of Liability

In addition to the product warranty described above, the state and local laws and regulations provide financial compensation for the product's power connection (including violation of implied terms and warranties). The company hereby declares that the terms and conditions of the product and the policy cannot and can only legally exclude all liability within a limited scope.

9. Datasheet

Model	SUN-3K-SG04LP1-24-AU	SUN-3K-SG04LP1-AU	SUN-3.6K-SG04LP1-AU	SUN-5K-SG04LP1-AU	SUN-6K-SG04LP1-AU
Battery Input Data					
Battery Type	Lead-acid or Li-Ion				
Battery Voltage Range(V)	20-30V	40-60V			
Max. Charging Current(A)	140A	70A	90A	120A	135A
Max. Discharging Current(A)	140A	70A	90A	120A	135A
Charging Curve	3 Stages / Equalization				
External Temperature Sensor	Optional				
Charging Strategy for Li-Ion Battery	Self-adaption to BMS				
PV String Input Data					
Max. DC Input Power(W)	3900W	3900W	4680W	6500W	7800W
PV Input Voltage(V)	370V (125V~500V)				
MPPT Range(V)	150~425V				
Full Load DC Voltage Range	300~425V				
Start-up Voltage(V)	125V				
PV Input Current(A)	13A	13A	13A+13A	13A+13A	13A+13A
Max.PV Isc(A)	17A	17A	17A+17A	17A+17A	17A+17A
No. of MPPT Trackers	1	1	2	2	2
No. of Strings Per MPPT Tracker	1	1	1+1	1+1	1+1
AC Output Data					
Rated AC Output and UPS Power(W)	3000w	3000w	3600w	5000w	6000w
Max. AC Output Power(W)	3300w	3000w	3600w	5000w	6000w
Peak Power(off grid)	2 times of rated power, 10 S				
AC Output Rated Current(A)	13A	13A	15.7A	21.7A	26.1A
Max. AC Current(A)	13A	13A	15.7A	21.7A	26.1A
Max. Continuous AC Passthrough(A)	35A				40A
Power Factor	0.8 leading to 0.8 lagging				
Output Frequency and Voltage	50Hz; 230V/240V 0.85Un-1.1Un				
Grid Type	Single Phase				
Current Harmonic Distortion	THD<3% (Linear load<1.5%)				
Efficiency					
Max. Efficiency	97.60%				
Euro Efficiency	96.50%				
MPPT Efficiency	>99%				
Protection					
PV Arc Fault Detection	Integrated				
PV Input Lightning Protection	Integrated				
Anti-islanding Protection	Integrated(Active Frequency Shift)				
PV String Input Reverse Polarity Protection	Integrated				
Insulation Resistor Detection	Integrated				
Residual Current Monitoring Unit	Integrated				
Output Over Current Protection	Integrated				
Output Shorted Protection	Integrated				
Surge Protection	DC Type II / AC Type III				

Model	<i>SUN-3K- SG04LP1-24-AU</i>	<i>SUN-3K- SG04LP1-AU</i>	<i>SUN-3.6K- SG04LP1-AU</i>	<i>SUN-5K- SG04LP1-AU</i>	<i>SUN-6K- SG04LP1-AU</i>
Certifications and Standards					
Grid Regulation	CEI 0-21,VDE-AR-N 4105,NRS 097,IEC 62116,IEC 61727,G99,G98, VDE 0126-1-1,RD 1699,C10-11				
EMC/Safety Regulation	IEC/EN 62109-1,IEC/EN 62109-2, IEC/EN 61000-6-1, IEC/EN 61000-6-2,IEC/EN 61000-6-3,IEC/EN 61000-6-4				
General Data					
Operating Temperature Range(C)	-40~60 C , >45 C Derating				
Cooling	Smart cooling				
Noise(dB)	<30 dB(A)				
Communication with BMS	RS485; CAN				
Weight(kg)	14			15.1	
Size(mm)	330W×433H×238D				
Protection Degree	IP65				
Installation Style	Wall-mounted				
Warranty	5 years				

10.Package and transport inverter

Usually placed inverter in the packing box with tape sealing, if the inverter cannot reoccupy, you can choose a cheap carton for packaging. Carton requirements must meet the size of the inverter and can support inverter machine overall weight.

Series frequency converter in the process of moving, please note: handle with care, do not touch the inverter, put as flat as possible.

11.Disposing of the inverter

Do not dispose of inverter together with household waste. Please accordance with the disposal regulations for electronic waste which apply at the installation site at that time. Ensure that the old unit and, where applicable, any accessories are disposed of in a proper manner.

12. Appendix I

Definition of RJ45 Port Pin for BMS

No.	RS485 Pin	CAN Pin
1	RS485B	--
2	RS485A	GND
3	GND	--
4		CANH
5		CANL
6	GND	--
7	RS485A	--
8	RS485B	--

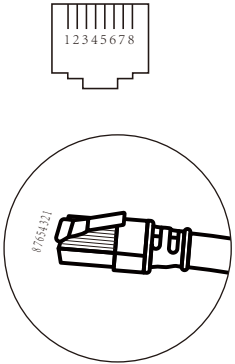

RS485 Port

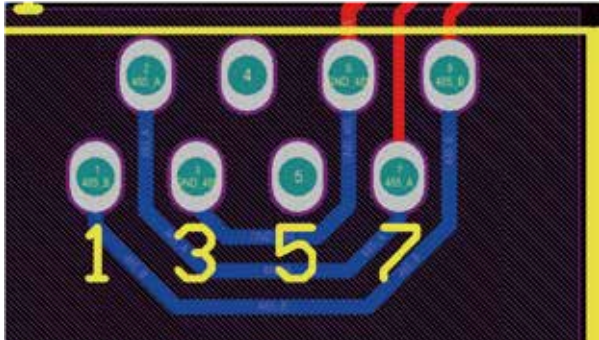

CAN Port

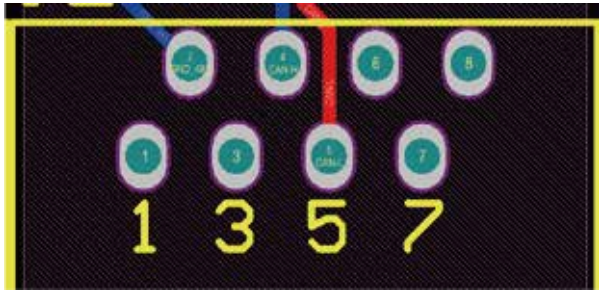

Meter_CON port

This port is used to connect the energy meter.

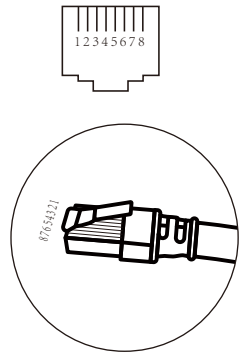
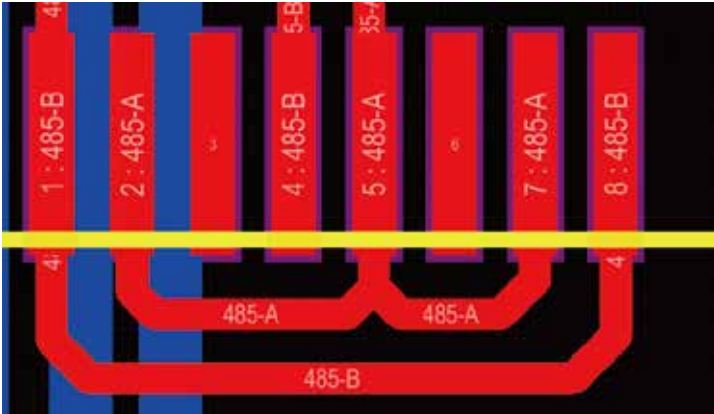

No.	RS485 Pin
1	RS485B
2	RS485A
3	
4	RS485B
5	RS485A
6	
7	RS485A
8	RS485B

Definition of RJ45 Port Pin for DRM Port

No.	Modbus port
1	DRM1/5
2	DRM2/6
3	DRM3/7
4	DRM4/8
5	REF-GEN/0
6	D-GND
7	NetDRM_7
8	NetDRM_7

DRM port

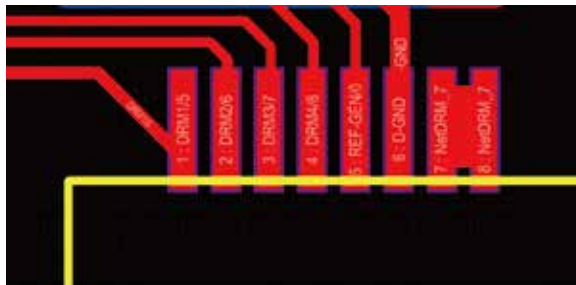
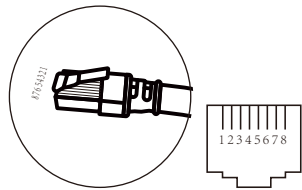

13. Appendix II

- 1. Split Core Current Transformer (CT) dimension: (mm)
- 2. Secondary output cable length is 4m.

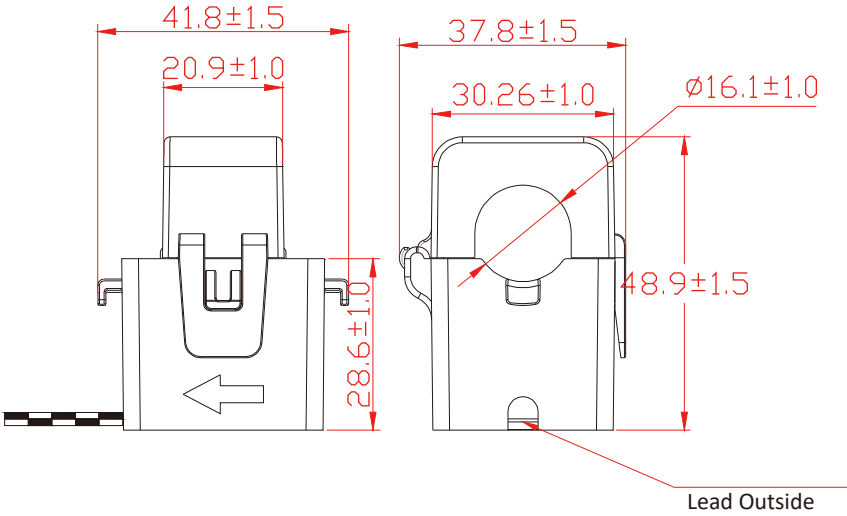

NINGBO DEYE INVERTER TECHNOLOGY CO., LTD.

Add: No.26-30, South Yongjiang Road, Beilun, 315806, Ningbo, China

Tel: +86 (0) 574 8622 8957

Fax: +86 (0) 574 8622 8852

E-mail: service@deye.com.cn

Web: www.deyeinverter.com